



ORMAZABAL



**Medium Voltage Switchgear
and Switches**



**Medium Voltage Switchgear up to 24 kV, 1250 A
SF₆-insulated, Modular Design**

Type: GAE, Series GAE1250

Medium-Voltage Switchgear up to 24 kV, SF₆-insulated, Modular Design, Type GAE, Series GAE1250

Index

General Information/Description	3	Fuse arrangement, selection of fuses	25
Benefits of SF ₆ -insulated, metal-encapsulated, modular switchgear assemblies	3	Fuse selection	25
Features	3	Exchanging an HV fuse	25
Applications	3	Front panel	26
Types of section	4	Gas leakage indication	26
Key to type references of sections	5	Pressure switch/ Density monitor	26
Key to add-on type references	5	Phase sequence indication	26
The HV compartment	6	Voltage display and testing	27
Drives	6	Voltage detection system in sealed version	27
Cable connection compartments	6	Voltage indication plug	27
Operation	6	Single-line diagram of a voltage indicator	27
Busbars	6	Phase sequence indication by interface tester	27
Cable retention brackets	6	Capacitive voltage indication ledge with built-in three-phase continuous indication and permanent self monitoring	28
Arc fault protection	6	Short-circuit indicator	29
Quality	6	Selection	29
Voltage transformer	7	T connection fittings	29
Current transformer	7	Accessories for the system	30
SF₆ the insulating and arc quenching medium	8	Operating levers	30
Technical Data	9	Cable clamps	30
Switchgear panels (rated values)	9	Size I	30
Standards	9	Size II	30
GNVL vacuum circuit-breaker with stored energy operated ON and OFF	10	Coupling and bolt connection kits	30
Three-position isolating switch in the current path (rated values)	10	Arc fault protection, panel installation	31
Three-position load-break switches (rated values)	11	Protection technology	32
Three-position circuit-breaker with stored energy operated OFF (rated values)	12		
Earthing switch (rated values)	12		
Range	13		
Outgoing feeder panel with vacuum circuit-breaker Type -1LSV-/6/	13		
Outgoing feeder panel with vacuum circuit-breaker Type -1LSV-/6/	14		
Outgoing panel with vacuum circuit-breaker Type -1LSVG-/6/	15		
Busbar riser panel with isolating switch Type -1HT-/6/	16		
Cable riser panel with isolating switch Type -1AT-/6/	17		
Bus-sectionalizer panel with SF ₆ circuit-breaker based on arc quenching coil Type -1LSF-/6/	18		
Cable panel with load-break switch and vertically arranged bushings Type -1K-/4/	19		
Cable panel with load-break switch and horizontally arranged bushings Type -1K-/6/	20		
Transformer feeder panel with fused load-break switch Type -1TS-/4/	21		
Busbar earthing panel with earthing switch Type -1E-/4/	22		
Metering panel with busbar riser Type -1M1-/12,5/	23		
Switching systems	24		
Three-position load-break switch, three-position circuit-breaker	24		
Function principle of the arc quenching coil	24		
The vacuum switching chamber	24		
Vacuum switching with an axial magnetic field	24		

Medium-Voltage Switchgear up to 24 kV, SF₆-insulated, Modular Design, Type GAE, Series GAE1250

General Information/Description

General Information/Description

Benefits of SF₆-insulated, metal-encapsulated, modular switchgear assemblies

With the GAE1250 series switchgear assemblies, Ormazabal Systems Division meets the international requirements of its customers for SF₆-insulated switchgear.

- ✓ Largely climate resistant
- ✓ Maintenance-free concept with SF₆-pressurised containers as a hermetically sealed pressure system
- ✓ Minimum space requirement
- ✓ Comprehensive personnel protection
- ✓ High level of functional reliability
- ✓ Great reliability of supply
- ✓ Great operator safety
- ✓ Great versatility due to availability of circuit-breaker, isolator and load-break switch sections
- ✓ Straightforward side-by-side fitting of sections by means of inner cone plug-in systems for the busbar connection
- ✓ Up to four-fold cable connection systems in circuit-breaker sections
- ✓ Metal-encapsulated plug-in voltage transformer can be retrofitted
 - optionally on the busbar side or on the outgoing side on circuit-breaker sections
 - optionally on the busbar side at riser panels
 - optionally with isolating/earthing switch
- ✓ Conventional current transformers can be easily exchanged together outside of the SF₆-pressurised container

Features

The GAE1250 series switchgear assemblies are type-tested, factory-built, metal-encapsulated SF₆-insulated switchgear installations made up of sections.

Applications

The GAE system up to 1250 A is eminently suitable for use in substations and switching stations, and also as load centres:

- In buildings with medium-voltage network infrastructure, e.g. in railway stations, department stores, hospitals, barracks, law courts, administrative buildings, etc.
 - Primary-level main distribution board/incomers/feeders,
 - Power stations (own production/stand-by power supply),
- In environmental projects with medium-voltage network infrastructure, e.g. in wind energy, biogas, sludge digestion, resource-recycling/-recovery plant, etc.
 - Primary-level main distribution boards,
 - Combined heating & power stations.



Front view



Front view with open front cover

Medium-Voltage Switchgear up to 24 kV, SF₆-insulated, Modular Design, Type GAE, Series GAE1250

General Information/Description

Types of section

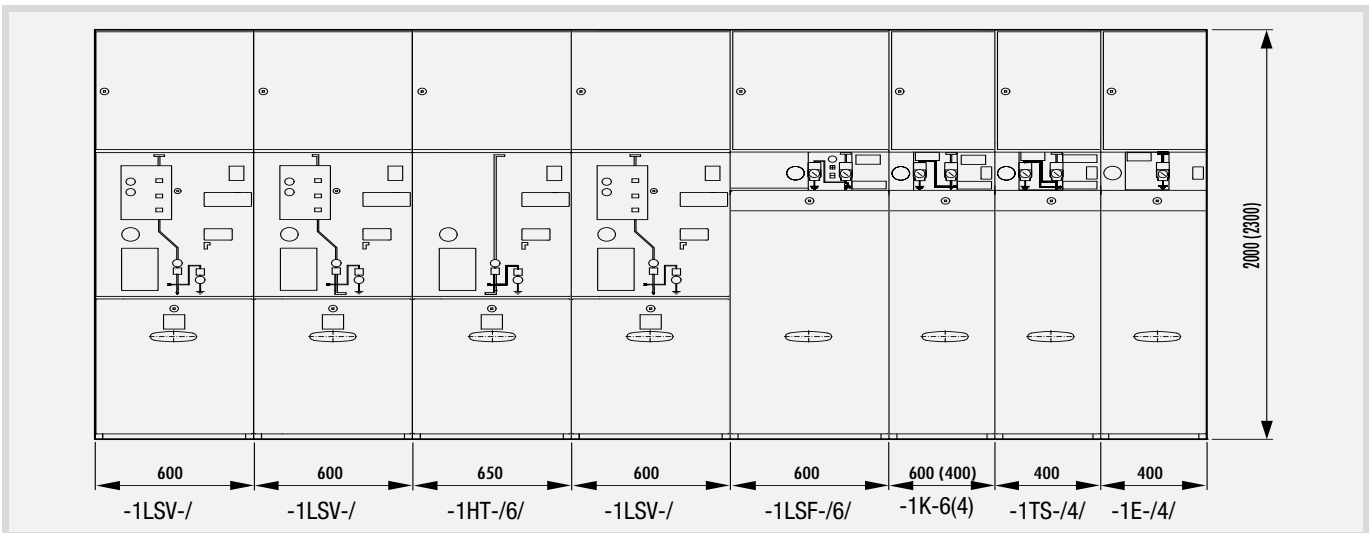

Examples of fittings

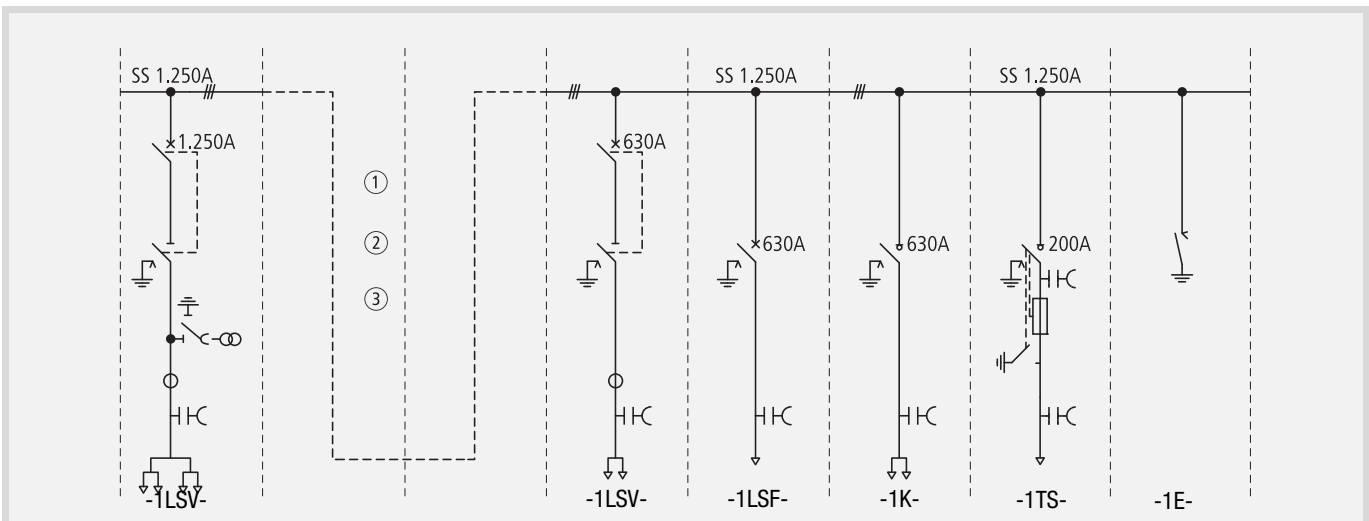

Variants of bus-sectionalizer and riser panels

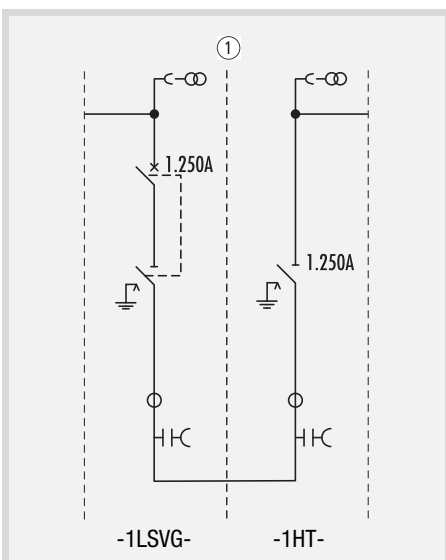

Bus-sectionalizer circuit-breaker panel -1LSVG- and busbar riser panel with isolating switch -1HT-

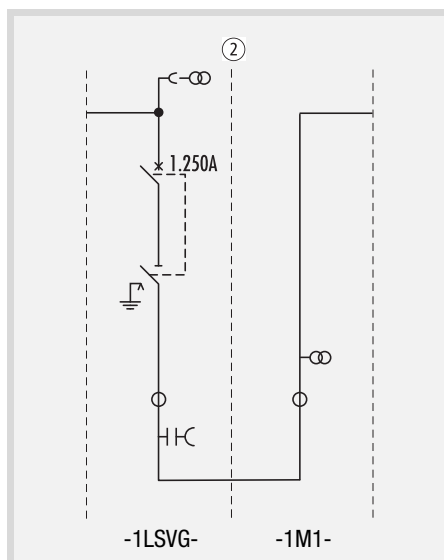

Bus-sectionalizer circuit-breaker panel -1LSVG- and metering panel as busbar panel -1M1-

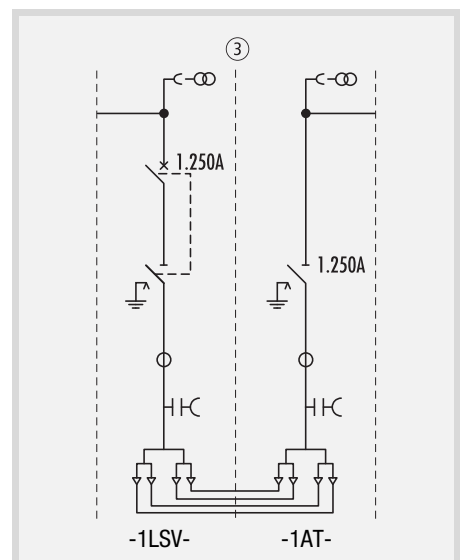

Outgoing circuit-breaker panel -1LSV- and cable riser panel -1AT- with cable bridge

Medium-Voltage Switchgear up to 24 kV, SF₆-insulated, Modular Design, Type GAE, Series GAE1250

General Information/Description

Key to type references of panels

① ② ③ ④ ⑤ ⑥ ⑦ ⑧ ⑨

GAE1250 x / x / x / x – x / x - x

- ① Family name: **Gas-insulated Expandable**
- ② Series: 1250 A
- ③ Types of panel:
- 1LSV-** = outgoing panel with vacuum circuit-breaker
 - 1LSVG-** = bus-sectionalizer panel with vacuum circuit-breaker
 - 1HT-** = busbar riser panel with isolating switch
 - 1AT-** = cable riser panel with isolating switch
 - 1LSF-** = outgoing panel with circuit-breaker based on arc quenching coil
 - 1K-** = cable panel with load-break switch
 - 1TS-** = transformer outgoing panel with fused load-break switch
 - 1E-** = busbar earthing panel with earthing switch
 - 1M1-** = metering panel with busbar riser
- ④ Panel width:
- 4 = 400 mm
 - 5 = 500 mm
 - 6 = 600 mm (650 mm with -1AT- and -1HT- sections)
 - 12.5 = 1250 mm
- ⑤ Rated voltage:
- 12 = 12 kV
 - 24 = 24 kV
- ⑥ Rated busbar current :
- 630 = 630 A
 - 1250 = 1250 A
- ⑦ Rated outgoer current:
- 200 = 200 A
 - 630 = 630 A
 - 1250 = 1250 A
- ⑧ Rated short-time current:
- 16 = 16 kA
 - 20 = 20 kA
- ⑨ Seconds of rated short-time current: 3 = 3 s

Key to add-on type references

Panels with optional voltage transformer at panel -1LSV-, -1LSVG-, -1HT-, -1AT-

Example:

① ② ③ ④

GAE1250-1LSV-/6/12/1250–1250/20-3 **y y y y**

- ① Version of cable connection bushing
- A1 = single
 - A2 = double
- ② Version of voltage metering
- Sp = voltage metering
- ③ Place of voltage metering
- SS = on the busbar side
 - Ab = on the outgoing side
- ④ Connection type with/without isolating and earthing switch underneath voltage transformer
- mTr = with isolator
 - oTr = without isolator

Medium-Voltage Switchgear up to 24 kV, SF₆-insulated, Modular Design, Type GAE, Series GAE1250

General Information/Description

The HV compartment

This is a gas-tight welded tank made from stainless steel, which houses all the live parts including the busbars. The incoming and outgoing power feeders, as well as the connection of the fuses is made through cast-resin bushings that are individually tested for maintenance of the maximally admissible partial discharge values ($TE \leq 2 \text{ pC}$). Each HV compartment is equipped with a stainless steel bursting membrane that is specifically designed for the individual tank.

Drives

The heavy-duty spring- or stored-energy operated drives are located above the HV compartment on the bus-sectionalizer panels with load-break switches or with circuit-breakers. On bus-sectionalizer panels with vacuum circuit-breakers they are fitted in front of the HV compartment. While the spring operated drives of ring cable sections do not need to be tested, the tripping function of the transformer- and circuit-breaker sections must be tested once every 10 years. But, due to the materials selected, there is no need for maintenance even here.

Cable connection compartments

are present on all panel sections and always made arc-proof. They are separated from one panel to the next by sheet steel intermediate walls. Inspections or work can be carried out in this way although the cable connection zone of the neighbouring panel is live. The front covers can be interlocked against the corresponding earthing switch. The front cover can only be opened when the earth is present. If required, an anti-reverse interlock can also be made available. This prevents the corresponding load-break switch from being switched onto a live busbar when the termination zone is open (front cover removed). The mechanism can be operated only with the front cover in place and the latch closed. The earthing switch at the cable outgoer is not incorporated in this interlock and is switchable even when the terminal zone is open (necessary for cable testing).

Deeper front covers are available to allow for double cable connection systems.

Operation

The mechanisms must be operated via the external drive shafts that are included in the mimic diagram. They include operating lever, 1 × load-break switch or circuit-breaker, 1 × earthing switch. Conventional operability is ensured due to the clearly structured mimic diagram and the easy-to-operate rotary handles. On the vacuum circuit-breakers, the switching spring is tensioned using a cranking handle for manual or emergency operation. The release operation is effected via push-button.

Busbars

are located in the HV compartment. The busbars of the individual sections or blocks of panels are linked to one another via special bushings including controlled silicone insulation and coupling pieces.

Cable retention brackets

These consist of galvanized pliable metal parts. Thanks to a special screwable design, they can be adjusted in height and depth enabling any of the cable terminations normally used for SF₆ systems to be applied and the cables to be fastened by means of cable clamps without difficulty.

Arc fault protection

The switching- and terminal compartments have been tested for arc-fault resistance to VDE 0671 Part 200 Appendix A "Internal arc faults", as well as to IEC 62271-200. Criteria 1 to 5 are satisfied. This arc fault qualification IAC AFL is present as standard in systems with arc-proof terminal compartments. For installation of the system, see the relevant particulars on Page 31.

The gases that emanate in the event of an arc fault are disposed of downwards into the cable well/cable duct in the standard version of the system.

In addition, there is a version where the panel floor is closed and pressure relief takes place via a rear absorber channel towards the top. The panel depth is thus increased to appr. 1150 mm.

By help of this rear absorber channel the pressure data within switchgear rooms will be reduced by appr. 60%.

Switchgear related pressure calculations can be enquired as part of services at the sales department of Ormazabal GmbH.

Quality

To be able to ensure and verify the quality, Ormazabal Systems Division (F&G) has installed a comprehensive Quality Management System.

The system complies with ISO 9001: 2000 as well as ISO 14001: 1996.

Routine testing of panels and systems as a matter of course includes the various tests to VDE 0670/IEC 62271 as well as the testing of customer-specific device configurations.

For example:

- Function tests of devices,
- Rated AC withstand voltage test 1 min,
- Testing of all auxiliary devices such as auxiliary contacts, shunt trip releases, remote operators, protective mechanisms (relays), measuring instruments,
- Function testing of the capacitive measuring device,
- Function testing of short-circuit indicators (where present).

Medium-Voltage Switchgear up to 24 kV, SF₆-insulated, Modular Design, Type GAE, Series GAE1250

General Information/Description

Voltage transformer

Plug-in, metal-encapsulated, single-pole voltage transformers to IEC 60044-2 and VDE 0414 Part 2 are optionally flanged directly above the gas tank to the bus-sectionalizer panels with vacuum circuit-breaker -1LSV(G)-/6/, the riser sections -1HT-/6/ and the cable riser sections -1AT-/6/.

They are optionally switched as busbar voltage transformers or outgoer voltage transformers.

An upstream isolating or earthing switch in SF₆ is optionally available (with outgoing voltage transformers it is standard). This isolating or earthing switch is operated via a drive feature that is located behind the interlocked front cover of the cable termination area. The drive feature must be equipped with a padlock.

The voltage transformers can be optionally supplied with certifiable or calibrated measuring core.



Current transformer

In outgoing panels and bus sectionalizer panels with circuit-breakers and those with load-break switches, low-voltage ring- and spectacle-core current transformers to IEC 600441-1 and VDE 0414 Part 1 are laid around the extended external cone bushings.

The protective and optional measuring cores are together built into a transformer block.

The voltage transformers can be optionally supplied with certifiable or calibrated measuring core.

The current transformers can be fitted or exchanged easily without intervention in the gas tank.

In addition, it is possible to use split-core current transformers laid around the earthed cable screens of the single-core cables in the cable connection compartment or the cable duct.

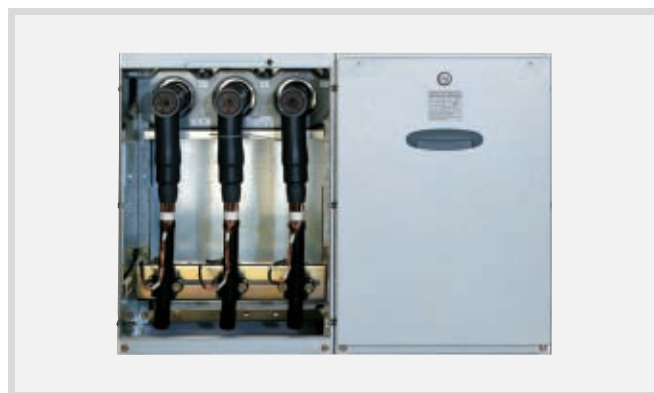

Medium-Voltage Switchgear up to 24 kV, SF₆-insulated, Modular Design, Type GAE, Series GAE1250

SF₆ the insulating and arc quenching medium

SF₆ the insulating and arc quenching medium

Sulphur hexafluoride (SF₆) gas has in recent years increasingly found its way also into medium-voltage load switching systems, having been previously successfully used mainly in circuit-breakers up to highest voltage levels.

This system change is taking place worldwide, since each of the previously used insulating and arc-quenching media, such as air, oil and solid materials, have their own more or less serious disadvantages:

- Air-insulated systems take up a great deal of space and, in extreme climatic or environmental conditions, require maintenance.
- Oil-insulated systems (as still predominantly used in Anglo-Saxon countries) although on the whole well protected against external influences, pose a considerable safety risk in the event of an internal fault.
- Solids-insulated systems (e.g. by cast resin), in the final analysis, are air-insulated devices and have the same maintenance problems, but much aggravated due to their compact construction.

SF₆ as insulating medium has a high degree of dielectric strength thereby enabling the construction of **very compact** systems that furthermore are **maintenance free** since all the live electric assembly parts have to be encapsulated.

With the actuating mechanics also largely removed from environmental influences, the user therefore gets a product that will do long-term duty **without maintenance**.

SF₆ is a non-poisonous, inert, electronegative gas that is heavier than air. In addition to the high insulating capability already mentioned, it also has extremely effective arc-quenching properties. At the high temperatures arising in the circuit-breaking arc, SF₆ separates into its constituent parts. When it cools, these regenerate to restore the SF₆-gas. This process of regeneration is supported by aluminium oxide (Al₂O₃) present in the system. It means that the volume of gas originally introduced remains unchanged and suffices for the entire service life of the system or mechanism. An evaluation of the advantages and potential theoretical risks has shown that at present, there are no technically and ecologically worthwhile alternatives in sight.

The high operational safety of the system (external influences such as humidity, conductive dust, etc. have no effect) virtually excludes arc-faults. Should such a fault nevertheless occur, than the pressure release diaphragm (rupturing disk) responds.

There are detailed instructions for use of such a SF₆ system, issued by the German Trade Association. **The SF₆ gas contained in this system must be reused – if necessary after reprocessing – and must not in be allowed to escape into the atmosphere. Ormazabal Systems Division will take care of the disposal for you against payment for the expense, should you not wish to dispose of a system yourself. This offer will hold good even after the system has been in operation for 25 to 30 years, at the applicable charge.**

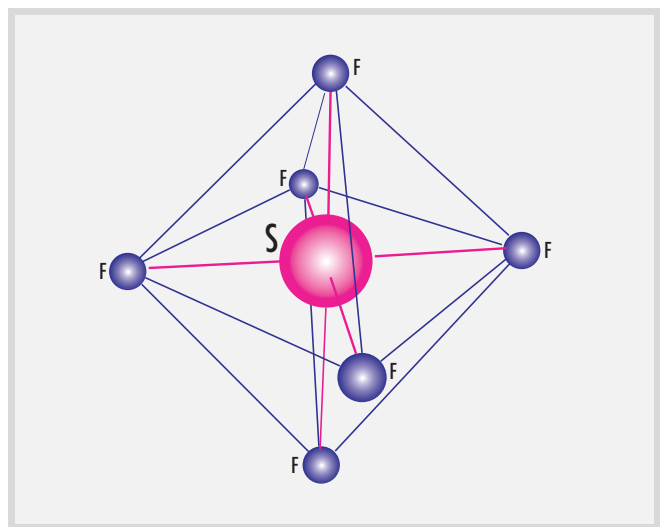

Medium-Voltage Switchgear up to 24 kV, SF₆-insulated, Modular Design, Type GAE, Series GAE1250

Technical Data

Technical Data

Switchgear panels (rated values)

		Rated voltage U_r			
		7.2 kV	12 kV	17.5 kV	24 kV ¹⁾
Rated insulation level					
Rated power-frequency withstand voltage, AC U_d	kV	20	28	38	50
Rated lightning impulse withstand voltage U_p	kV	60	75	95	125
Rated frequency f_r	Hz	50/60	50/60	50/60	50/60
Rated normal current I_r	For busbars	A	1250	1250	1250
Rated short-time current I_k	at $t_k = 3$ s	Up to kA	20	20	16
Rated peak withstand current I_p		Up to kA	50	50	40
Rated short-circuit making current I_{ma}		Up to kA	50	50	40
Ambient temperature T		°C	- 5 to +40 ^{2), 3)}		
	With reduced current ratings	°C	Above +40		
Relative humidity		%	Maximally 95		
Rated filling pressure of insulating gas at 20 °C and 101.3 kPa		kPa	130 (30 kPa overpressure)/LSF panel 150 (50 kPa overpressure)		
Insulating gas			SF ₆		
Rated density of insulating gas		kg/m ³	7.9		
Encapsulation of the HV compartment		IP	Hermetically welded tank, IP65		
Encapsulation of the fuse compartment		IP	Single-pole arcing-free encapsulation and 3-phase metal encapsulation, IP44		
Encapsulation of the drive housing, relay cabinet		IP	IP44/IP3XD		
Enclosure of the cable connection compartment		IP	IP44		
Internal arc test compliant with VDE 0671, Part 200, Appendix AA and resp. IEC 62271-200		kA	IAC AFL 20 kA, 1 s for HV compartments		
		kA	IAC AFL 20 kA, 1 s for terminal compartments		
Colour of panel paint finish		RAL	7035 (light grey)		
Loss of service continuity category			LSC 2A		
Partition class			PM		

1) Higher rated voltage (25 kV) on request.

2) Operation at lower temperatures on request.

3) Depending to secondary technic.

Standards

The Type GAE switchgear installation complies with the following Standards and Regulations:

IEC 60265-1 (62271-103*)	/ VDE 0670 Part 301 (VDE 0671 Part 103*)
IEC 60282-1	/ VDE 0670 Part 4
IEC 62271-1 (IEC 60694**)	/ VDE 0670 Part 1000 (VDE 0671 Teil 1*)
IEC 62271-100	/ VDE 0671 Part 100
IEC 62271-102	/ VDE 0671 Part 102

IEC 62271-105	/ VDE 0671 Part 105
IEC 62271-200 (60298**)	/ VDE 0671 Part 200 (VDE 0670 Part 6**)

* = future

** = up to now

Medium-Voltage Switchgear up to 24 kV, SF₆-insulated, Modular Design, Type GAE, Series GAE1250

Technical Data

GNVL vacuum circuit-breaker with stored energy operated ON and OFF

Circuit-breaker panel -1LSV(G)-				Rated voltage U_r			
				7.2 kV	12 kV	17.5 kV	24 kV ¹⁾
Rated normal current of the feeder circuits	(optional)	I_r	A	1250 (630)	1250 (630)	1250 (630)	1250 (630)
Rated short-time current	For systems with $t_{th} = 3$ s	I_k	kA	20	20	16	16
Rated peak withstand current		I_p	kA	50	50	40	40
Rated short-circuit making current		I_{ma}	kA	50	50	40	40
Rated short-circuit breaking current		I_{sc}	kA	20	20	16	16
Rated cable-charging breaking current		I_c	A	50	50	50	50
DC components			%	33	33	33	33
Rated transient recovery voltage		U_c					
	Peak value		kV	21	21	41	41
	Rate of rise		kV/ μ s	0.34	0.34	0.47	0.47
Pole factor				1.5	1.5	1.5	1.5
Mechanical operations		n		10000 \times ³⁾			
Class				E1/M2/C2	E1/M2/C2	E1/M2/C2	E1/M2/C2
Insulating medium				SF ₆			
Quenching medium				Vacuum			
Drive				Motor-Spring-operated stored energy mechanism			
Number of poles				3			
Number of isolating gaps per pole				1			
Opening time			ms	45			
Closing time			ms	38			
Distance between pole centres			mm	150			
Temperature class			•C	- 5 to +40 ²⁾			
Installation				Indoor			
Rated switching sequence (optional)				0 – 0.3 s – C0 – 15 s– C0			

1) Higher rated voltage (25 kV) on request.

2) Operation at lower temperatures on request.

3) Higher values upon request.

Three-position isolating switch in the current path (rated values)

Sections -1LSV(G)-, -1HT-, -1AT-				Rated voltage U_r			
				7.2 kV	12 kV	17.5 kV	24 kV ¹⁾
Rated normal current I_r	(optional)	I_r	A	1250 (630)	1250 (630)	1250 (630)	1250 (630)
Rated short-time current	For systems with $t_k = 1$ s	I_k	kA	20	20	16	16
	For systems with $t_k = 3$ s	I_k	kA	20	20	16	16
Rated peak withstand current		I_p	kA	50	50	40	40
Operations – mechanically admissible		n		10000 \times	10000 \times	100000 \times	10000 \times
Class				M2	M2	M2	M2

1) Higher rated voltage (25 kV) on request.

Medium-Voltage Switchgear up to 24 kV, SF₆-insulated, Modular Design, Type GAE, Series GAE1250

Technical Data

Three-position load-break switches (rated values)

Cable panel -1K-, transformer outgoing panel -1TS-					Rated voltage U_r			
					7.2 kV	12 kV	17.5 kV	24 kV ⁶⁾
Rated normal current for	Ring cable feeder circuits	I_r	A	630	630	630	630	
	Transformer feeder circuits ¹⁾	I_r	A	200	200	200	200	
Rated short-time current ²⁾	for systems with $t_k = 3s$	I_k	kA	20	20	16	16	
Rated peak withstand current ²⁾		I_p	kA	50	50	40	40	
Rated short-circuit making current for	Transformer feeder circuits ³⁾	I_{ma}	kA	50	50	40	40	
	Ring cable feeder circuits	I_{ma}	kA	50	50	40	40	
Switching capacity for multi-purpose load-break switches to IEC 60265-1 and VDE 0670 Part 301								
Test sequence 1	Rated mainly active load-breaking current	At 20 operations	I_1	A	630	630	630	630
		At 100 operations	I_1	A	630	630	630	630
		At 5 %	I_1	A	31.5	31.5	31.5	31.5
Test sequence 2a	Rated distribution line closed-loop breaking current, $10 \times$	I_2	A	630	630	630	630	
Test sequence 4a	Rated cable-charging breaking current	I_{4a}	A	50	50	40	40	
Test sequence 5	Rated short-circuit making current	I_{ma}	kA	50	50	40	40	
–	Rated no-load transformer breaking current	I_3	A	4)	4)	4)	4)	
Switching capacity in the event of an earth fault								
Rated earth-fault disconnect current		I_{6a}	A	160	160	160	160	
Rated cable-charging breaking current in the event of an earth fault		I_{6b}	A	100	100	100	100	
Switching capacity to IEC 62271 - 105								
Rated transfer current		Device Type TS	$I_{transfer}$	A	1900	1900	1500	1500
Rated transfer current	On request	Device Type LTS	$I_{transfer}$	A	2800	2800	–	–
Operations, ring cable panel, -1K-								
Rated mainly active load-breaking current		n		$100 \times$	$100 \times$	$100 \times$	$100 \times$	
Rated short-circuit making current		n		$5 \times$	$5 \times$	$5 \times$	$5 \times$	
Mechanically admissible		n		$1000 \times$ ⁵⁾	$1000 \times$ ⁵⁾	$1000 \times$ ⁵⁾	$1000 \times$ ⁵⁾	
Class				E3/M1	E3/M1	E3/M1	E3/M1	

1) Dependent on HV fuse link size.

2) In the transformer feeder circuit, these values are limited by HV fuses.

3) Dependent on the HV fuse cut-off current.

4) Tested exemplary in accordance with the above Standard for 400 kVA and 1000 kVA transformers at 12 kV and 24 kV.

5) Higher values upon request.

6) Higher rated voltage (25 kV) on request.

Medium-Voltage Switchgear up to 24 kV, SF₆-insulated, Modular Design, Type GAE, Series GAE1250

Technical Data

Three-position circuit-breaker with stored energy operated OFF (rated values)

Outgoing panel with SF ₆ circuit-breaker -1LSF- Switching capability acc. to IEC 62271-100, test duty I_{100a} is not required				Rated voltage U_r			
				7.2 kV	12 kV	17.5 kV	24 kV ²⁾
Rated normal current of the feeder circuits	I_r	A	250/630	250/630	250/630	250/630	
Rated short-time current	For systems with $t_{th} = 3$ s	I_k	kA	20	20	16	16
Rated peak withstand current		I_p	kA	50	50	40	40
Rated short-circuit making current		I_{ma}	kA	50	50	40	40
Rated short-circuit breaking current		I_{sc}	kA	20	20	16	16
Rated cable-charging breaking current		I_c	A	50	50	50	50
Rated switching sequence		–		0 – 3 min – C0 – 3 min – C0			
Operations at							
Rated short-circuit making current		n		5 ×	5 ×	5 ×	5 ×
Rated short-circuit breaking current		n		20 × ¹⁾	20 × ¹⁾	22 × ¹⁾	22 × ¹⁾
Rated normal current and mechanically admissible		n		2000 ×	2000 ×	2000 ×	2000 ×
Class				M1/E2	M1/E2	M1/E2	M1/E2

1) Higher values, on request.

2) Higher rated voltage (25 kV) on request.

Earthing switch (rated values)

Sections -1LSV(G)-, -1LSF-, -1K-, -1TS-, -1E-, -1HT-, -1AT-				Rated voltage U_r			
				7.2 kV	12 kV	17.5 kV	24 kV ²⁾
Earthing function of the three-position switch							
Rated short-circuit making current	I_{ma}	kA	50	50	40	40	
Rated short-time current	I_k	kA	20	20	16	16	
Earthing function downstream of HV fuse							
Rated short-circuit making current	I_{ma}	kA	6.3	6.3	6.3	6.3	
Rated short-time current	I_k	kA	2.5	2.5	2.5	2.5	
Operations							
Rated short-circuit making current 50 kA	n		5 ×	5 ×	5 ×	5 ×	
Mechanically admissible	n		1000 × ¹⁾	1000 × ¹⁾	1000 × ¹⁾	1000 × ¹⁾	
Class			E2	E2	E2	E2	

1) Higher values, on request.

2) Higher rated voltage (25 kV) on request.

Medium-Voltage Switchgear up to 24 kV, SF₆-insulated, Modular Design, Type GAE, Series GAE1250

Range

Range

Outgoing feeder panel with vacuum circuit-breaker Type -1LSV-/6/

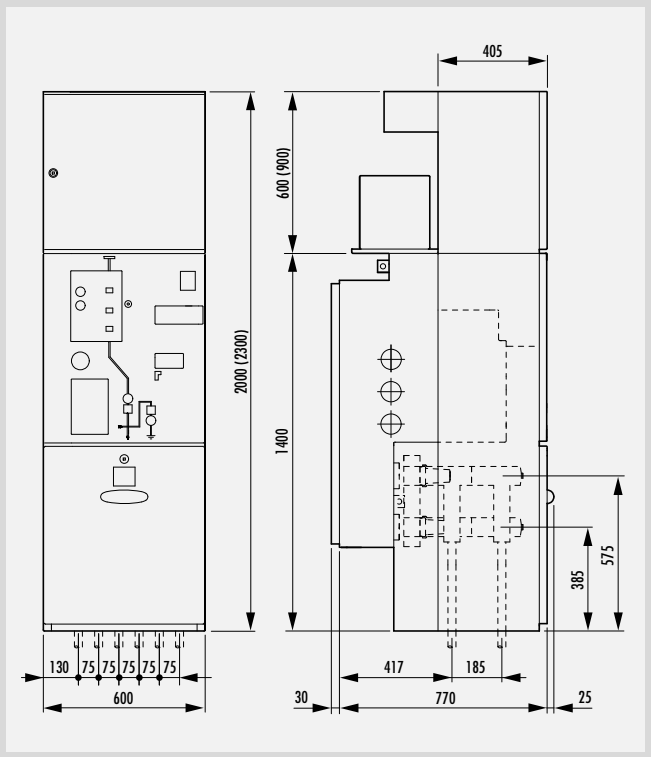

Profile drawing



Front view showing open cable termination area with fourfold cable termination



Side view with metal-encapsulated, single-pole voltage transformers fitted

Medium-Voltage Switchgear up to 24 kV, SF₆-insulated, Modular Design, Type GAE, Series GAE1250 Range

Outgoing feeder panel with vacuum circuit-breaker Type -1LSV-/6/

Variants

- 1LSV-/6/12/1250-630/20-3
- 1LSV-/6/24/1250-630/16-3
- 1LSV-/6/12/1250-1250/20-3
- 1LSV-/6/24/1250-1250/16-3

Standard equipment

- Vacuum circuit-breaker with stored energy operated– ON and OFF –:
 - Auxiliary contacts: 10 NO and 10 NC,
 - Tripping device – ON, OFF – DC or AC,
 - Signalling contact for "Starting sections charged",
 - Mechanical counter,
- SF₆ three-position isolating and earthing switch:
 - interlocked with circuit-breaker,
 - Manual operation,
 - Earthing switch with spring operated– ON and OFF–,
- 3-pole SF₆ -insulated busbar in the SF₆ compartment,
- On both sides of the SF₆-gas tank: inner cone plug-in systems for external busbar connection,
- Capacitive voltage indication ledges in relay cabinet front cover,
- Gas leakage indication
- Pressure relief in the event of arcing directed into the cable well, panel floor open,
- Lockable operators,
- Arc-fault resistant cable termination compartments,
- Single set of cable connection bushings for maximally double cable connection via external cone plug XLPE 2 × 1 × 500 mm²:
 - One connection plug replaceable for surge arrester,
- Relay- and control compartment height 600 mm.

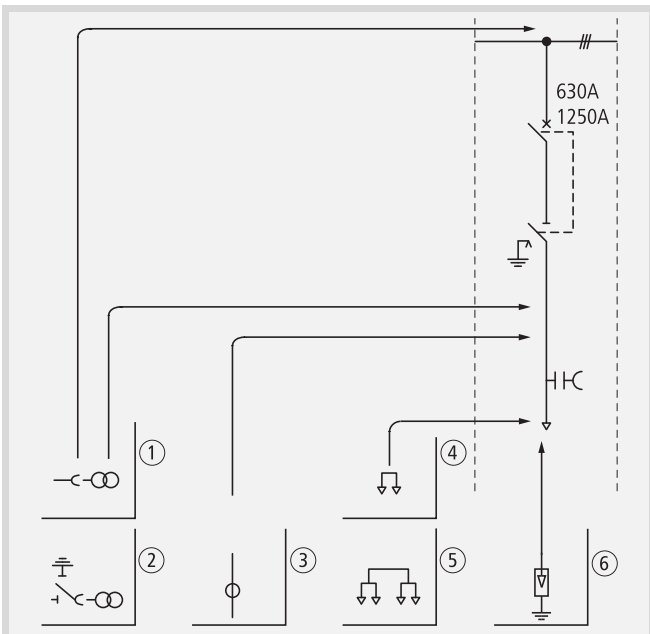

- ① Plug-in voltage transformers
- ② Plug-in voltage transformers with isolating- and earthing feature
- ③ Current transformer
- ④ Maximally double cable connection
- ⑤ Maximally fourfold cable connection with double set of bushings
- ⑥ Surge arrester

Optional

- Accessories for vacuum circuit-breakers:
 - Motor operator,
 - Undervoltage trip block,
 - Fleeting contact for switch failure indication,
 - Pump blocking relay,
 - Electrical starting preventer (blocking magnet),
 - Varistor module ≥ 60 V DC,
- Accessories for SF₆ three-position isolating and earthing switch:
 - Auxiliary contact module for isolating switch, max. 3 NO, 3 NC,
 - Auxiliary contact module for earthing switch, max. 2 NO, 2 NC,
 - Motor operator for isolating switch – on request,
- Double set of cable connection bushings for maximally fourfold cable connection via external cone plug XLPE 4 × 1 × 300 mm²:
 - One connection plug replaceable for surge arrester,
- Anti-reverse interlock for cable termination front covers,
- Plug-in, metal-encapsulated, single-pole voltage transformer, optional:
 - Calibrated,
 - Switched on the busbar side,
 - Switched on the outgoing side,
 - Without isolating-/earthing feature below the transformer within the SF₆-gas tank (option for busbar metering),
 - With isolating-/earthing feature below the transformer within the SF₆-gas tank
- Relay- and control compartment height 900 mm,
- Current transformer trip release for pulsed release or via auxiliary current transformer,
- Capacitive voltage indication ledge with built-in three-phase continuous indication and permanent self monitoring in relay cabinet front cover (→ page 28),
- Short-circuit indicator in relay cabinet front cover (→ page 29),
- SF₆ pressure monitoring:
 - Pressure switch with auxiliary contact,
 - Density monitor with auxiliary contact,
- In the event of arcing, pressure relief via the rear absorber channel towards the top, panel floor closed, overall depth approx. 1150 mm (→ page 31),
- Protective relay by agreement,
- Single-pole or 3-pole system protection current transformer (and measuring current transformer, optionally calibrated) as ring-core (spectacle core) transformer laid around the external cone bushing, by agreement,
- Layout of relay compartment and front panel, by agreement,
- Cable clamps.

Medium-Voltage Switchgear up to 24 kV, SF₆-insulated, Modular Design, Type GAE, Series GAE1250

Range

Outgoing panel with vacuum circuit-breaker Type -1LSVG-/6/

Variants

-1LSVG-/6/12/1250-1250/20-3

-1LSVG-/6/24/1250-1250/16-3

Standard equipment

- Vacuum circuit-breaker with stored energy operated – ON and OFF –:
 - Auxiliary contacts: 10 NO and 10 NC,
 - Tripping device – ON, OFF – DC or AC,
 - Signalling contact for "Starting sections charged",
 - Mechanical counter,
- SF₆ three-position isolating and earthing switch:
 - interlocked with circuit-breaker,
 - Manual operation,
 - Earthing switch with spring operated – ON and OFF –,
- 3-pole SF₆-insulated busbar in the SF₆ compartment,
- On one side of the SF₆-gas tank: inner cone plug-in systems for external busbar connection,
- Silicone insulated, controlled, external busbar to the riser panel -1HT-/6/,
- Capacitive voltage indication ledges in relay cabinet front cover,
- Gas leakage indication,
- Pressure relief in the event of arcing directed into the cable well, panel floor open,
- Lockable operators,
- Arc-fault resistant cable termination compartments,
- Relay- and control compartment height 600 mm.

Optional

- Accessories for vacuum circuit-breakers:
 - Motor operator,
 - Undervoltage trip block,
 - Fleeting contact for switch failure indication,

- Pump blocking relay,
- Electrical starting preventer (blocking magnet),
- Varistor module ≥ 60 V DC,
- Accessories for SF₆ three-position isolating and earthing switch:
 - Auxiliary contact module for isolating switch, max. 3 NO, 3 NC,
 - Auxiliary contact module for earthing switch, max. 2 NO, 2 NC,
 - Motor operator for isolating switch – on request,
- Anti-reverse interlock for connection front covers,
- Plug-in, metal-encapsulated, single-pole voltage transformer, optional:
 - Calibrated,
 - Switched on the busbar side,
 - Without isolating-/earthing feature below the transformer within the SF₆-gas tank (option for busbar metering),
 - With isolating-/earthing feature below the transformer within the SF₆-gas tank,
- Relay- and control compartment height 900 mm,
- Current transformer trip release for pulsed release or via auxiliary current transformer,
- Capacitive voltage indication ledge with built-in three-phase continuous indication and permanent self monitoring in relay cabinet front cover (→ page 28),
- SF₆ pressure monitoring:
 - Pressure switch with auxiliary contact,
 - Density monitor with auxiliary contact,
- In the event of arcing, pressure relief via the rear absorber channel towards the top, panel floor closed, overall depth approx. 1150 mm (→ page 31),
- Protective relay by agreement,
- Single-pole system protection current transformer (and measuring current transformer, optionally calibrated) as ring-core transformer laid around the external cone bushing, by agreement,
- Layout of relay compartment and front panel, by agreement.

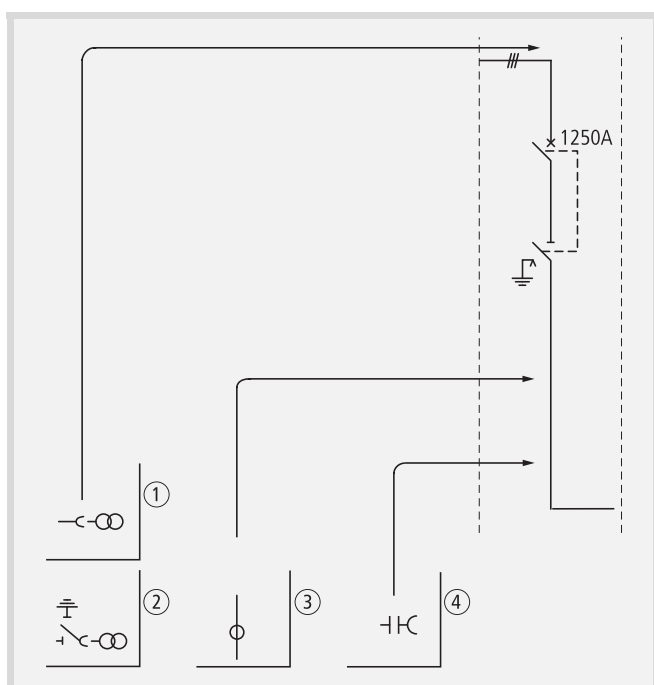

- ① Plug-in voltage transformers
 ② Plug-in voltage transformers with isolating- and earthing feature

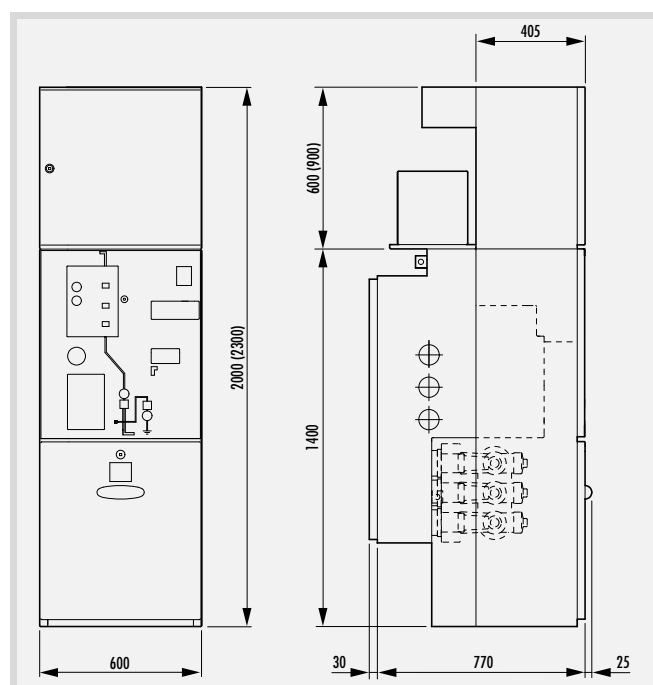

- ③ Current transformer
 ④ Capacitive voltage indication ledge

Medium-Voltage Switchgear up to 24 kV, SF₆-insulated, Modular Design, Type GAE, Series GAE1250 Range

Busbar riser panel with isolating switch Type -1HT-/6/

Variants

- 1HT-/6/12/1250-1250/20-3
- 1HT-/6/24/1250-1250/16-3

Standard equipment

- SF₆ three-position isolating and earthing switch:
 - interlocked,
 - Handle,
 - Earthing switch with spring operated – ON and OFF –,
- 3-pole SF₆ -insulated busbar in the SF₆ compartment,
- On one side of the SF₆-gas tank: inner cone plug-in systems for external busbar connection,
- Silicone insulated, controlled, external busbar to the bus-sectionalizer panel -1LSVG-/6/,
- Gas leakage indication
- Pressure relief in the event of arcing directed into the cable well, panel floor open,
- Lockable operators,
- Arc-fault resistant terminal compartments,
- Relay- and control compartment height 600 mm,
- Intermediate frame B = 50 mm to the bus-sectionalizer panel.

Optional

- Accessories for SF₆ three-position isolating and earthing switch:
 - Auxiliary contact module for isolating switch, max. 3 NO, 3 NC,
 - Auxiliary contact module for earthing switch, max. 2 NO, 2 NC,
 - Motor operator for isolating switch, on request,

- Electromechanical interlock between isolating switch and circuit-breaker in the bus-sectionalizer panel -1LSVG- /6/,
- Anti-reverse interlock for connection front covers,
- Plug-in, metal-encapsulated, single-pole voltage transformer, optional:
 - Calibrated,
 - Switched on the busbar side,
 - Without isolating-/earthing feature below the transformer within the SF₆-gas tank (option for busbar metering),
 - With isolating-/earthing feature below the transformer within the SF₆-gas tank,
- Relay- and control compartment height 900 mm,
- Capacitive voltage indication ledges in relay cabinet front cover,
- Capacitive voltage indication ledge with built-in three-phase continuous indication and permanent self monitoring in relay cabinet front cover (→ page 28),
- SF₆ pressure monitoring:
 - Pressure switch with auxiliary contact,
 - Density monitor with auxiliary contact,
- In the event of arcing, pressure relief via the rear absorber channel towards the top, panel floor closed, overall panel depth approx. 1150 mm (→ page 31),
- Single-pole measuring current transformer (optionally calibrated) as ring-core transformer laid around the external cone bushing of the external busbar, by agreement,
- Layout of relay compartment and front panel, by agreement.

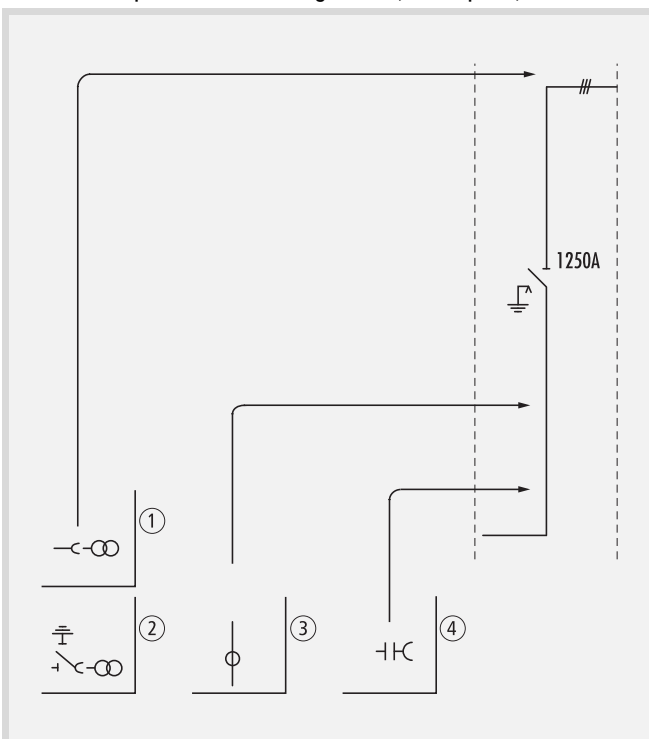

- ① Plug-in voltage transformers
- ② Plug-in voltage transformers with isolating- and earthing feature
- ③ Current transformer
- ④ Capacitive voltage indication ledge

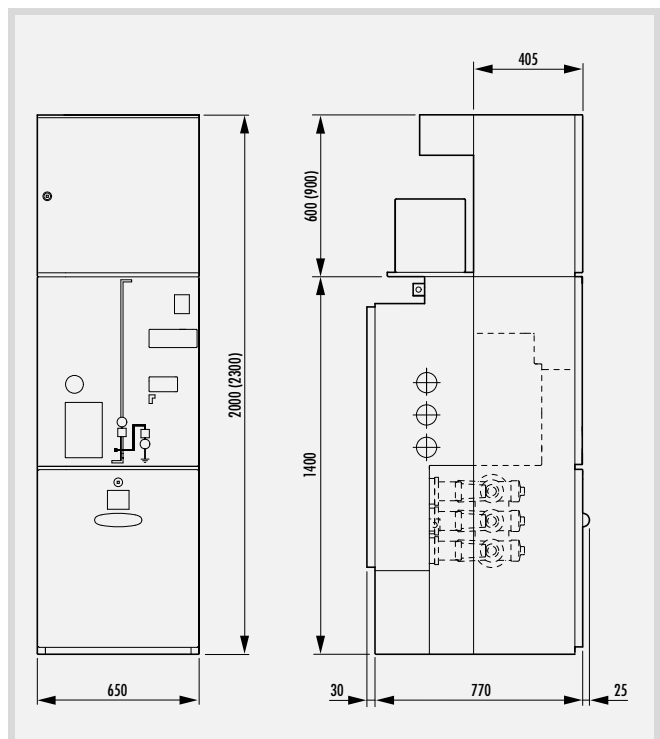

Medium-Voltage Switchgear up to 24 kV, SF₆-insulated, Modular Design, Type GAE, Series GAE1250

Range

Cable riser panel with isolating switch Type -1AT-/6/

Variants

- 1AT-/6/12/1250-630/20-3
- 1AT-/6/24/1250-630/16-3
- 1AT-/6/12/1250-1250/20-3
- 1AT-/6/24/1250-1250/16-3

Standard equipment

- SF₆ three-position isolating and earthing switch:
 - interlocked,
 - Handle,
 - Earthing switch with spring operated – ON and OFF –,
- 3-pole SF₆-insulated busbar in the SF₆ compartment,
- On both sides of the SF₆-gas tank: inner cone plug-in systems for external busbar connection,
- Gas leakage indication,
- Pressure relief in the event of arcing directed into the cable well, panel floor open,
- Lockable operators,
- Arc-fault resistant terminal compartments,
- Single set of cable connection bushings for maximally double cable connection via external cone plug XLPE 2 × 1 × 500 mm², (One connection plug replaceable for surge arrester),
- Relay- and control compartment height 600 mm,
- Intermediate frame B = 50 mm to the bus-sectionalizer panel.

Optional

- Accessories for SF₆ three-position isolating and earthing switch,
 - Auxiliary contact module for isolating switch, max. 3 NO, 3 NC,
 - Auxiliary contact module for earthing switch, max. 2 NO, 2 NC,

- Motor operator for isolating switch, on request,
- Electromechanical interlock between isolating switch and circuit-breaker in the sectionalizing circuit-breaker panel for cable coupling -1LSV-,
- Double set of cable connection bushings for maximally fourfold cable connection via external cone plug XLPE 4 × 1 × 300 mm²,
- Anti-reverse interlock for connection front covers,
- Plug-in, metal-encapsulated, single-pole voltage transformers, optional:
 - Calibrated,
 - Switched on the busbar side,
 - Without isolating-/earthing feature below the transformer within the SF₆-gas tank (option for busbar metering),
 - With isolating-/earthing feature below the transformer within the SF₆-gas tank,
- Relay- and control compartment, height 900 mm,
- Capacitive voltage indication ledges in relay cabinet front cover,
- Capacitive voltage indication ledge with built-in three-phase continuous indication and permanent self monitoring in relay cabinet front cover (→ page 28),
- SF₆ pressure monitoring:
 - Pressure switch with auxiliary contact,
 - Density monitor with auxiliary contact,
- In the event of arcing, pressure relief via rear absorber channel towards the top, panel floor closed, overall panel depth approx. 1150 mm (→ page 31),
- Single-pole measuring current transformers (optionally calibrated) as ring core transformer laid around the external cone bushing of the external busbar, by agreement,
- Layout of relay compartment and front panel, by agreement.

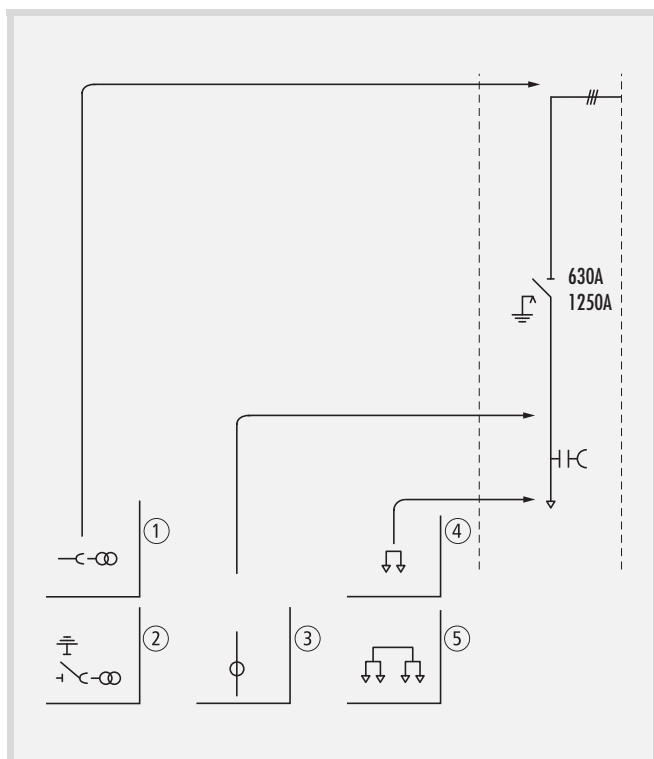

- ① Plug-in voltage transformers
- ② Plug-in voltage transformers with isolating- and earthing feature

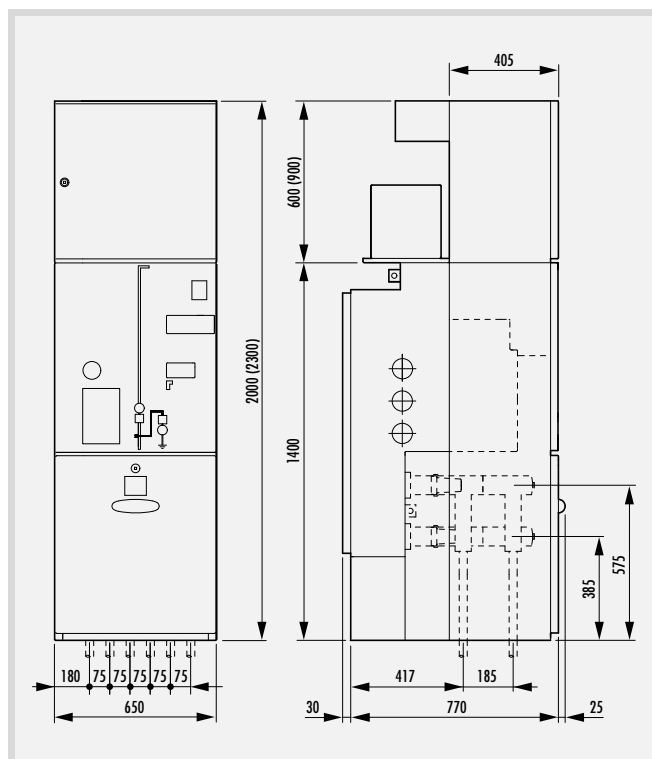

- ③ Maximally double cable connection
- ④ Maximally fourfold cable connection with double set of bushings

Medium-Voltage Switchgear up to 24 kV, SF₆-insulated, Modular Design, Type GAE, Series GAE1250 Range

Outgoing feeder panel with SF₆ circuit-breaker based on arc quenching coil Type -1LSF-/6/

Variants

- 1LSF-/6/12/1250-630/20-3
- 1LSF-/6/24/1250-630/16-3

Standard equipment

- SF₆ three-position circuit-breaker and earthing switch:
 - Including interlock,
 - Handle,
 - Circuit-breaker with spring operated – ON, and stored energy operated – OFF,
 - Earthing switch with spring operated – ON and OFF –,
- Manual Emergency-Stop push-button,
- 3-pole SF₆ insulated busbar in the SF₆ compartment,
- On both sides of the SF₆ gas tank: inner cone plug-in systems for external busbar connections,
- Capacitive voltage indication ledges,
- Gas leakage indication,
- Pressure relief in the event of arcing directed into the cable well, panel floor open,
- Lockable operators,
- Arc-fault resistant cable termination compartments,
- Single set of cable connection bushings for maximally double cable connection via external cone plug XLPE 2 × 1 × 500 mm², (One connection plug replaceable for surge arrester),
- Relay- and control compartment, height 600 mm.

Optional

- Circuit-breaker
 - Motor operator for circuit-breaker,
 - Shunt trip release, AC, DC,
 - Auxiliary contacts: 3 NO and 3 NC,
- Auxiliary contact module for earthing switch, max. 2 NO, 2 NC,
- Anti-reverse interlock for cable termination front covers,
- Relay- and control compartment, height 900 mm,
- Current transformer trip release for pulsed release or via auxiliary current transformer,
- Auxiliary current transformer,
- Capacitive voltage indication ledge with built-in three-phase continuous indication and permanent self monitoring in relay cabinet front cover (→ page 28),
- Short-circuit indicator in relay cabinet front cover (→ page 29),
- SF₆ pressure monitoring:
 - Pressure switch with auxiliary contact,
 - Density monitor with auxiliary contact,
- In the event of arcing, pressure relief via rear absorber channel towards the top, panel floor closed, overall panel depth approx. 1150 mm (→ page 31),
- Deeper front cover for double cable connection (depth + 61 mm),
- Protective relay by agreement,
- 3-pole system protection current transformer (and measuring current transformer, optionally calibrated) as ring-core (spectacle core) transformer laid around the external cone bushing, by agreement,
- Layout of relay compartment and front panel, by agreement,
- Cable clamps.

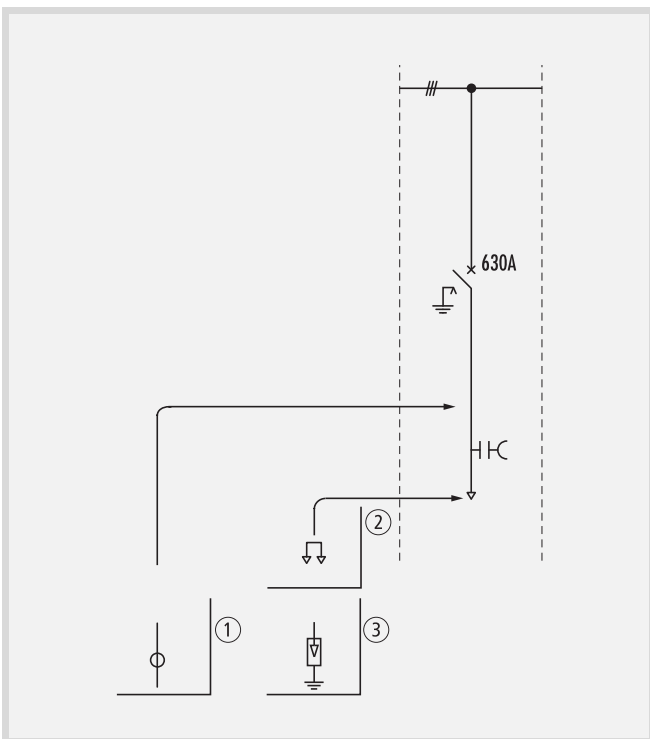

- ① Current transformer
- ② Maximally double cable connection
- ③ Surge arrester

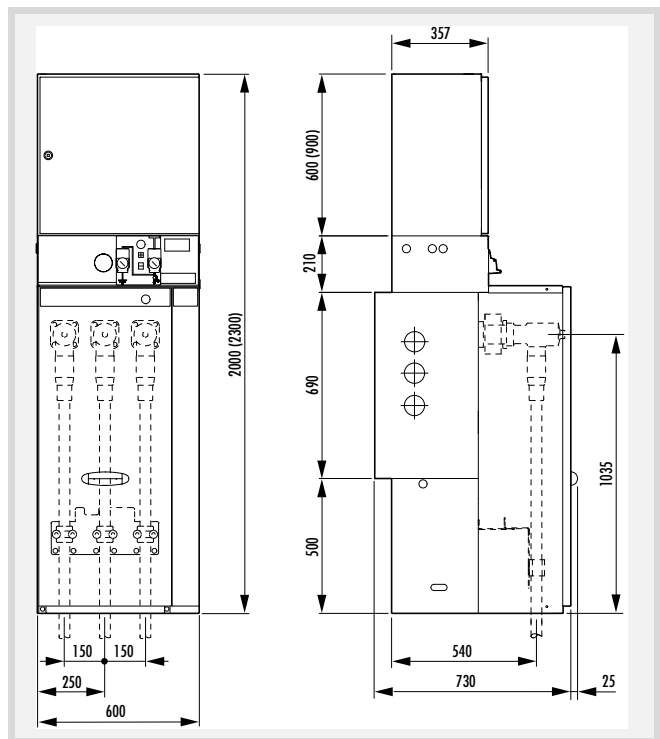

Medium-Voltage Switchgear up to 24 kV, SF₆-insulated, Modular Design, Type GAE, Series GAE1250

Range

Cable panel with load-break switch and vertically arranged bushings Type -1K-/4/

Variants

-1K-/4/12/1250-630/20-3

-1K-/4/24/1250-630/16-3

Standard equipment

- SF₆ three-position load-break and earthing switch:
 - Including interlock,
 - Manual operation,
 - Load-break and earthing switches with spring-operated – ON and OFF –,
- 3-pole SF₆-insulated busbar in the SF₆ compartment,
- On both sides of the SF₆-gas tank: inner cone plug-in systems for external busbar connection,
- Capacitive voltage indication ledges,
- Gas leakage indication
- Pressure relief in the event of arcing directed into the cable well, panel floor open,
- Lockable operators,
- Arc-fault resistant cable termination compartments,
- Single set of cable connection bushings for maximally double cable connection via external cone plug XLPE 2 × 1 × 500 mm², (One connection plug replaceable for surge arrester),
- Relay- and control compartment height 600 mm.

Optional

- Accessories for SF₆ three-position isolating and earthing switch:
 - Auxiliary contact module for isolating switch, max. 3 NO, 3 NC,
 - Auxiliary contact module for earthing switch, max. 2 NO, 2 NC,
 - Motor operator for load-break switch, on request,
- Anti-reverse interlock for cable termination front covers,
- Relay- and control compartment, height 900 mm,
- Capacitive voltage indication ledge with built-in three-phase continuous indication and permanent self monitoring in relay cabinet front cover (→ page 28),
- Short-circuit indicator (→ page 29),
- SF₆ pressure monitoring:
 - Pressure switch with auxiliary contact,
 - Density monitor with auxiliary contact,
- In the event of arcing, pressure relief via rear absorber channel towards the top, panel floor closed, overall panel depth approx. 1150 mm (→ page 31),
- Deeper front cover for double cable connection (depth + 61 mm),
- Layout of LV control compartment and front panel, by agreement,
- Cable clamps.

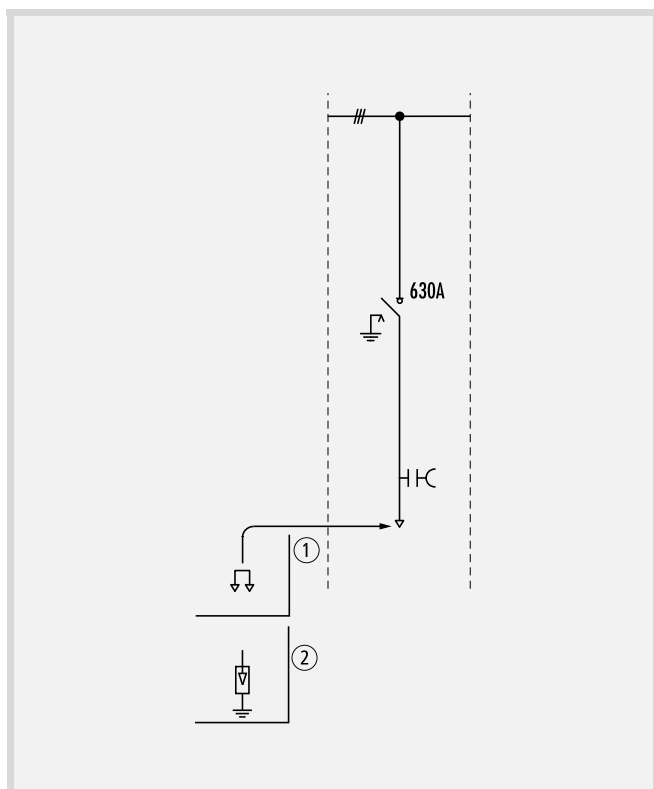

① Maximally double cable connection

② Surge arrester

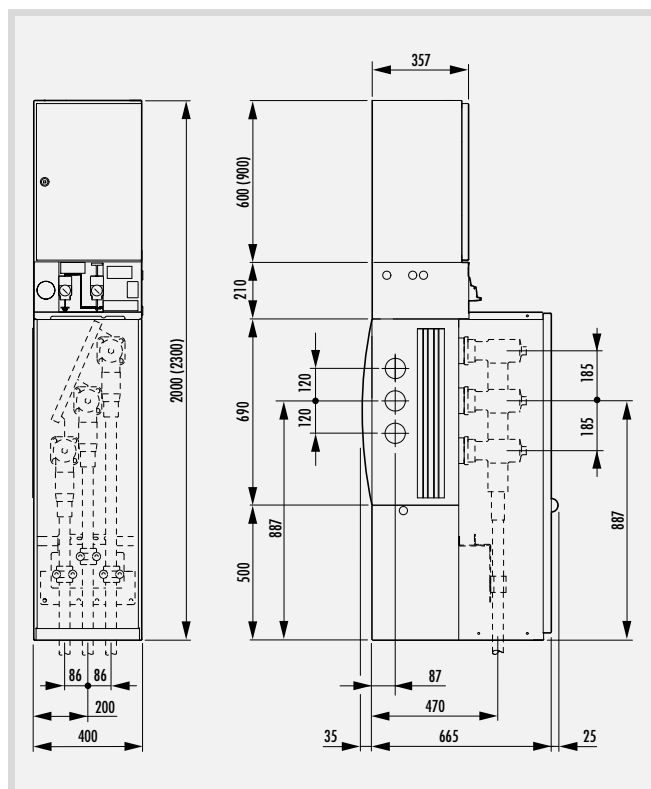

Medium-Voltage Switchgear up to 24 kV, SF₆-insulated, Modular Design, Type GAE, Series GAE1250

Range

Cable panel with load-break switch and horizontally arranged bushings Type -1K-/6/

Variants

- 1K-/6/12/1250-630/20-3
- 1K-/6/24/1250-630/16-3

Standard equipment

- SF₆ three-position load-break and earthing switch:
 - Including interlock,
 - Handle,
 - Load-break and earthing switches with spring-operated – ON and OFF –,
 - 3-pole SF₆-insulated busbar in the SF₆ compartment,
- On both sides of the SF₆ gas tank: inner cone plug-in systems for external busbar connection,
- Capacitive voltage indication ledges,
- Gas leakage indication
- Pressure relief in the event of arcing directed into the cable well, panel floor open,
- Lockable operators,
- Arc-fault resistant cable termination compartments,
- Single set of cable connection bushings for maximally double cable connection via external cone plug XLPE 2 × 1 × 500 mm², (One connection plug replaceable for surge arrester),
- Relay- and control compartment height 600 mm.

Optional

- Accessories for SF₆ three-position load-break and earthing switch:
 - Auxiliary contact module for isolating switch, max. 3 NO, 3 NC,
 - Auxiliary contact module for earthing switch, max. 2 NO, 2 NC,
 - Motor operator for load-break switch,
- Anti-reverse interlock for cable termination front covers,
- Relay- and control compartment, height 900 mm,
- Capacitive voltage indication ledge with built-in three-phase continuous indication and permanent self monitoring in relay cabinet front cover (→ page 28),
- Short-circuit indicator (→ page 29),
- SF₆ pressure monitoring:
 - Pressure switch with auxiliary contact,
 - Density monitor with auxiliary contact,
- In the event of arcing, pressure relief via rear absorber channel towards the top, panel floor closed, overall panel depth approx. 1150 mm (→ page 31),
- Deeper front cover for double cable connection (depth + 61 mm),
- Layout of LV control compartment and front panel, by agreement,
- Cable clamps.

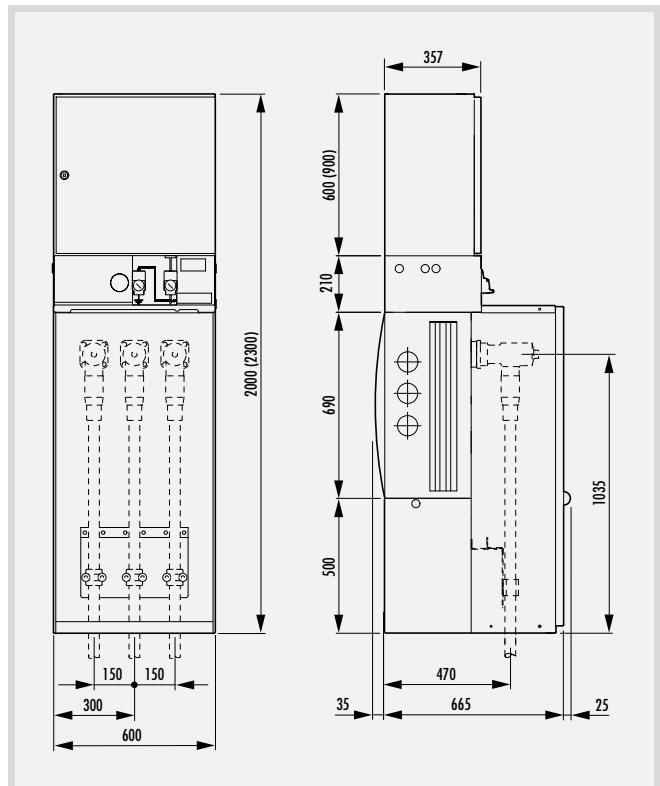
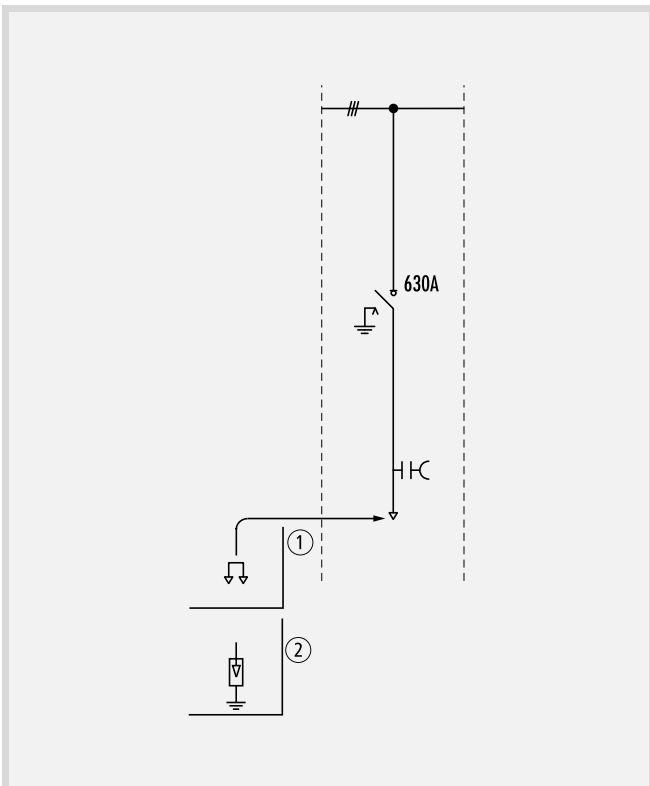

- ① Maximally double cable connection
- ② Surge arrester

Medium-Voltage Switchgear up to 24 kV, SF₆-insulated, Modular Design, Type GAE, Series GAE1250 Range

Transformer feeder panel with fused load-break switch Type -1TS-/4/

Variants

-1TS-/4/12/1250-200/20-3

-1TS-/4/24/1250-200/16-3

Standard equipment

- SF₆ three-position load-break and earthing switch:
 - Including interlock,
 - Manual operation,
 - Load-break switch with spring operated – ON, and stored energy operated – OFF,
 - Earthing switch with spring operated – ON and OFF –,
- Indication of tripped fuse,
- 3-pole SF₆-insulated busbar in the SF₆ compartment,
- On both sides of the SF₆-gas tank: inner cone plug-in systems for external busbar connection,
- 3-phase plug-on fuse arrangement,
- Earthing switch in SF₆ downstream of the HRC fuse,
- 3-pole slip-on type cable termination for transformer cables, maximally XLPE 1 × 240 mm²,
- Capacitive voltage indication ledges upstream and downstream of the fuse,
- Gas leakage indication,
- Pressure relief in the event of arcing directed into the cable well, panel floor open,
- Lockable operators,
- Arc-fault resistant terminal compartment,
- Relay- and control compartment, height 600 mm.

Optional

- Accessories for SF₆ three-position load-break and earthing switch:
 - Auxiliary contact module for load-break switch, max. 3 NO, 3 NC,
 - Shunt trip release, AC, DC,
 - Auxiliary contact module trip indication,
 - Motor operator for load-break switch,
 - Auxiliary contact module for earthing switch, max. 2 NO, 2 NC,
- Anti-reverse interlock for front covers,
- Relay- and control compartment, height 900 mm,
- Capacitive voltage indication ledge with built-in three-phase continuous indication and permanent self monitoring (→ page 28),
- SF₆ pressure monitoring:
 - Pressure switch with auxiliary contact,
 - Density monitor with auxiliary contact,
- In the event of arcing, pressure relief via rear absorber channel towards the top, panel floor closed, overall panel depth approx. 1150 mm (→ page 31),
- Deeper front cover for double cable connection (depth + 61 mm),
- Layout of LV control compartment and front panel, by agreement,
- Cable clamps.

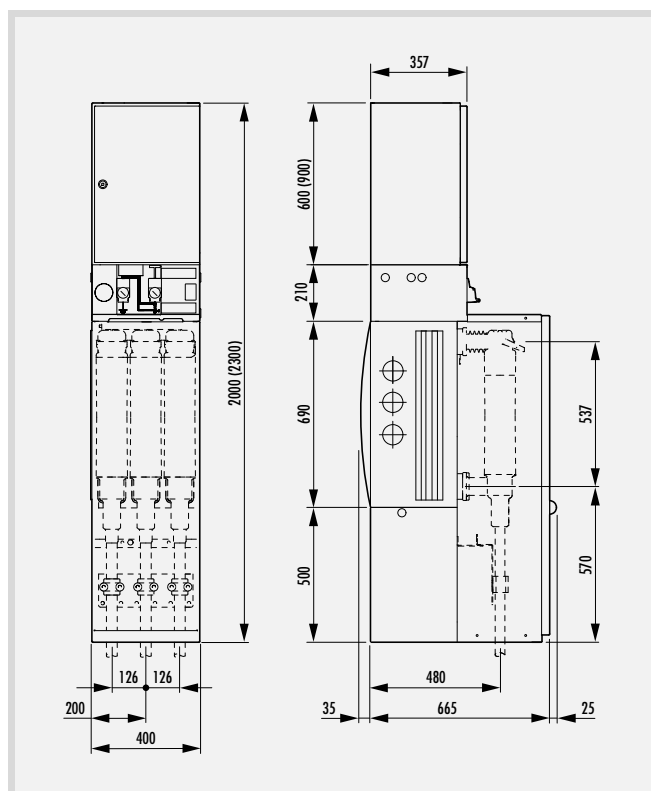
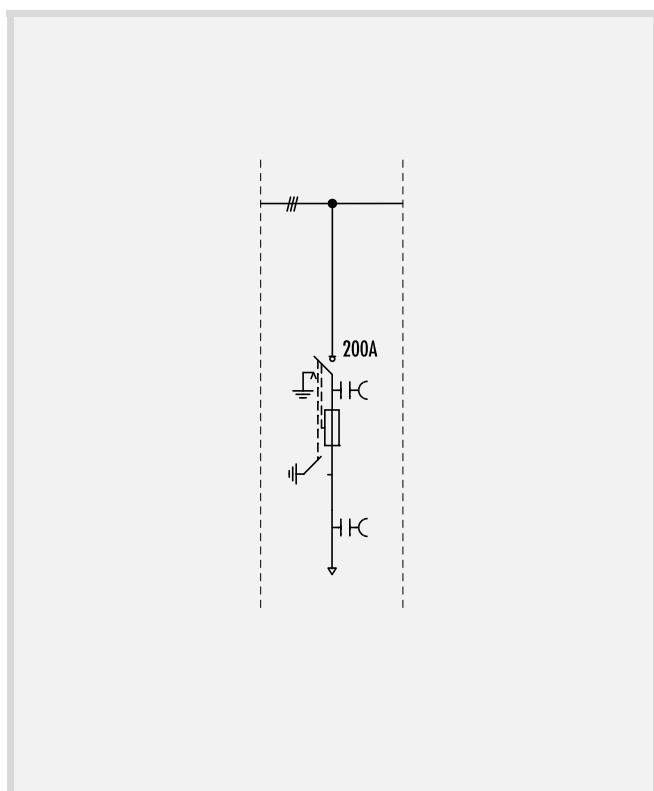

Medium-Voltage Switchgear up to 24 kV, SF₆-insulated, Modular Design, Type GAE, Series GAE1250 Range

Busbar earthing panel with earthing switch Type -1E-/4/

Variants

- 1E-/4/12/1250/20-3
- 1E-/4/24/1250/16-3

Standard equipment

- SF₆-insulated 3-pole earthing switch for busbar earthing:
 - Earthing function as three-position switch,
 - Manual operation,
 - Spring operated – ON and OFF –,
- 3-pole SF₆-insulated busbar in the SF₆ compartment,
- On both sides of the SF₆-gas tank: inner cone plug-in systems for external busbar connection,
- Earthed short-circuit bridge via vertical, frontal external cone bushing arrangement,
- Gas leakage indication,
- Pressure relief in the event of arcing directed into the cable well, panel floor open,
- Lockable operators,
- Arc-fault resistant terminal compartments,
- Relay- and control compartment height 600 mm.

Optional

- Earthing switch:
 - Auxiliary contacts: 2 NO and 2 NC,
- Electromechanical interlock,
- Relay- and control compartment, height 900 mm,
- SF₆ pressure monitoring:
 - Pressure switch with auxiliary contact,
 - Density monitor with auxiliary contact,
- In the event of arcing, pressure relief via rear absorber channel towards the top, panel floor closed, overall panel depth approx. 1150 mm (→ page 31),
- Layout of LV control compartment and front panel, by agreement.

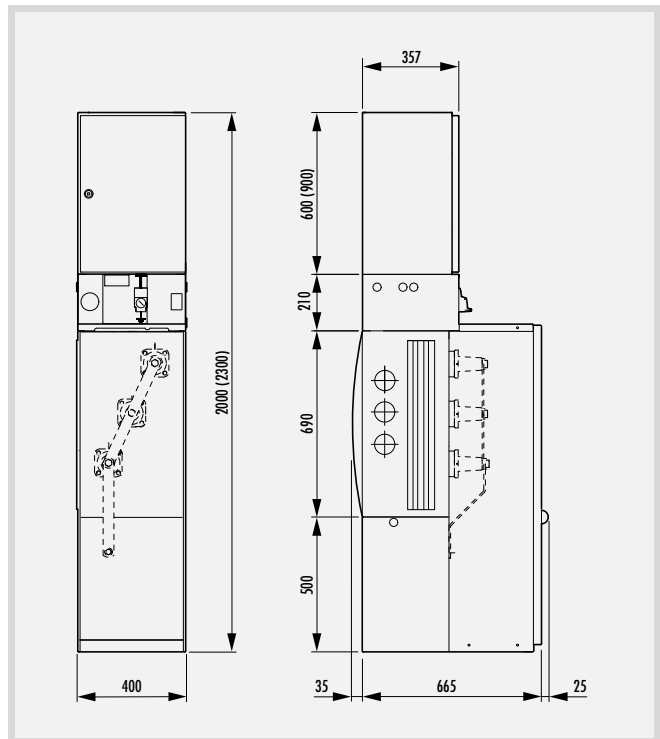
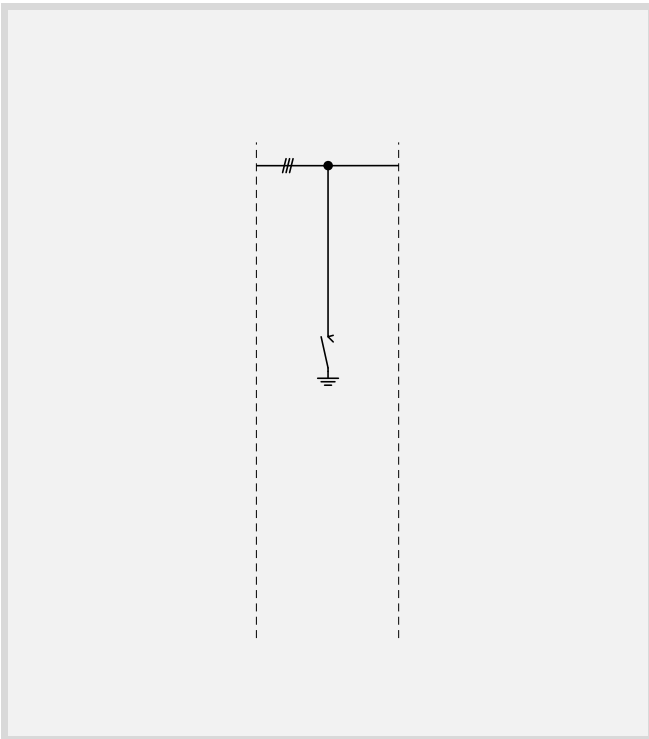

Medium-Voltage Switchgear up to 24 kV, SF₆-insulated, Modular Design, Type GAE, Series GAE1250

Range

Metering panel with busbar riser Type -1M1-/12,5/

Variants

- 1M1-/12,5/12/1250/20-3
- 1M1-/12,5/24/1250/16-3

Standard equipment

- 3-pole busbar for bus-sectionaliser circuit-breaker panel -1LSVG-,
- On one side of the metering panel: inner cone plug-in systems for external GAE busbar connections,
- Compact insulators - current- and/or voltage transformers, DIN 42660 part 8 resp. 9, IEC 600441, supplied by Ormazabal, or supplied by electricity supply company,
- Arc-fault resistant terminal compartments,
- Relay- and control compartment, height 600 mm.

Optional

- Locking facility for front covers, electricity supply company lock mechanism,
- Phase/earth bolt for connection of earthing and short-circuit kits D = 20 mm, M12,
- Phase/earth bolt for connection of earthing and short-circuit kits D = 25 mm, M16,
- Relay- and control compartment, height 900 mm,
- In the event of arcing, pressure relief via rear absorber channel towards the top, panel floor closed, overall panel depth approx. 1150 mm (→ page 31),
- Layout of LV control compartment and front panel, by agreement.

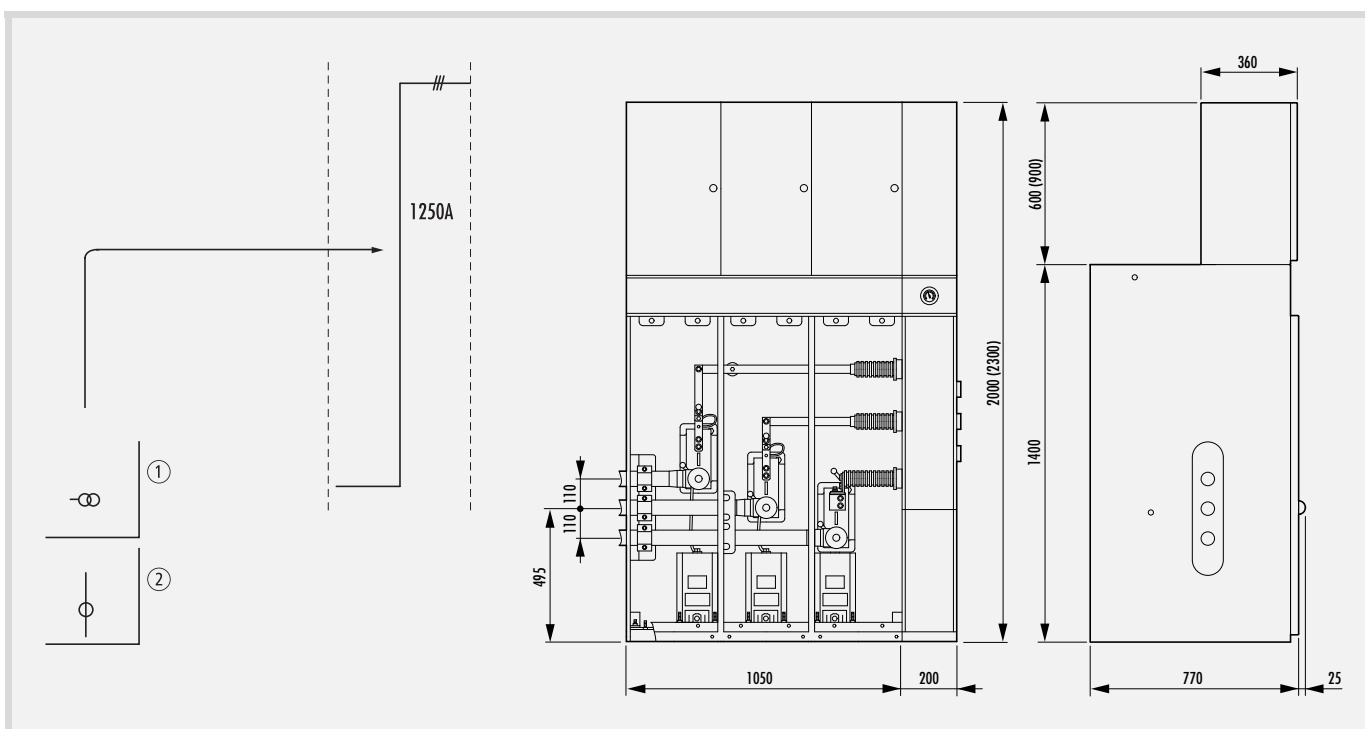

- ① Voltage transformer
- ② Current transformer

Medium-Voltage Switchgear up to 24 kV, SF₆-insulated, Modular Design, Type GAE, Series GAE1250

Switching systems

Switching systems

Three-position load-break switch, three-position circuit-breaker

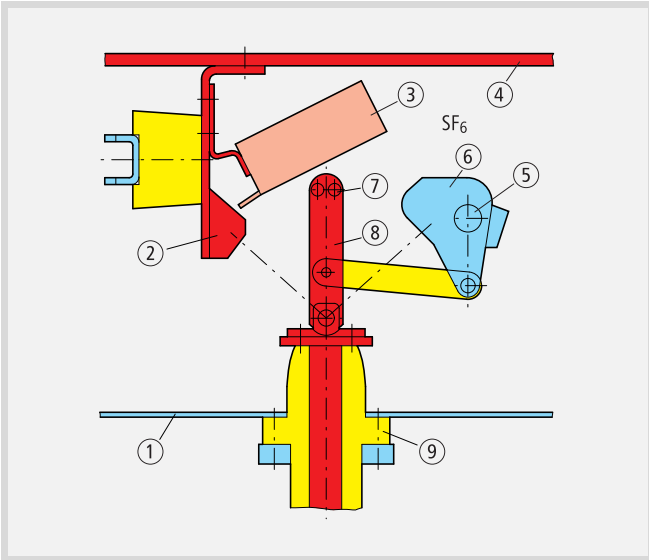

- ① Front gas tank
- ② Fixed contact, On
- ③ Arc quenching coil
- ④ Busbar
- ⑤ Drive shaft
- ⑥ Earthing contact
- ⑦ Special contact rivets
- ⑧ Blade contact
- ⑨ Bushing

Function principle of the arc quenching coil

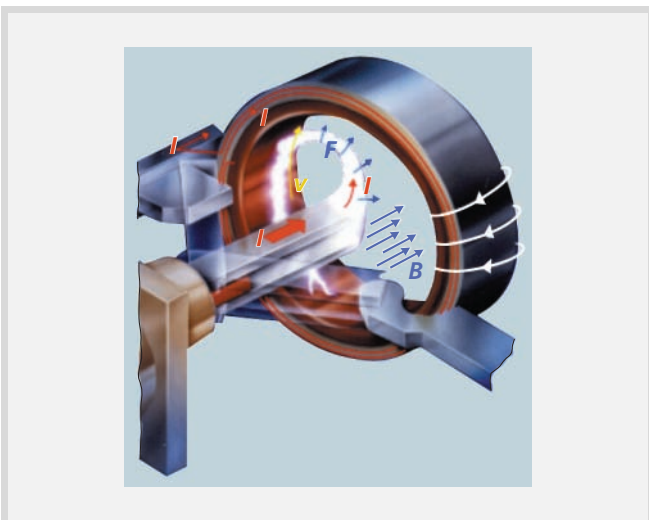

- I = Current
- B = Magnetic field generated by current I in the arc quenching coil
- F = Force exerted on the current-carrying switching arc
- v = Speed vector of the switching arc

The vacuum switching chamber

The vacuum switching chamber comprises the axially arranged large-area contact bodies in an evacuated metal-ceramic housing. The contacting surfaces of the contact bodies are covered in a special contact material. Two solid copper dies, one of which is movable, form the link to the terminal parts of the circuit-breaker. The vacuum-tight seal between the moving contact die and the vacuum housing is effected by metal concertina walls. The die is guided by means of a gliding bearing.

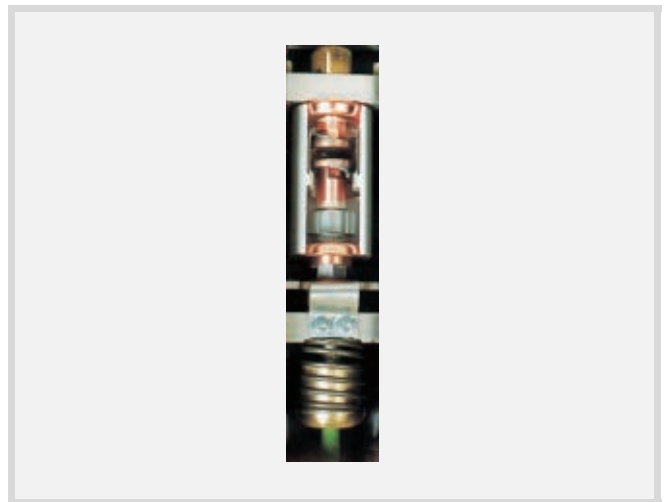

Vacuum switching with an axial magnetic field

On de-energization, an arc arises in the vacuum switching chamber from the moment of contact separation. Once the quenching distance has been attained, the arc extinguishes as the current passes through zero. The arc causes local melting of the contact surfaces. The metal that is vaporised during this process, condenses mainly on the contacts and only to a lesser extent on the screens surrounding the contacts. The arc interrupting current (normal chopping) of the vacuum switching chambers used is less than 5 A and causes only moderate overvoltages. Using an axial magnetic field in the vacuum switching chamber between the contacts achieves that even in the short-circuit current range, the metal vapour arc remains diffuse*. The thermal load on the contacts therefore, remains very small and contact burn is negligible.

* The arc is spread out rather than concentrated

Medium-Voltage Switchgear up to 24 kV, SF₆-insulated, Modular Design, Type GAE, Series GAE1250

Fuse arrangement, selection of fuses

Fuse arrangement, selection of fuses

The fuse arrangement within the panel -1TS- is a plug-in system. All the fuse components are coupled to the contacts via cast-resin bushings from outside of the gas tank. The plug-in system consists of the upper and the lower fuse holder. The plug-in parts, made from silicone rubber, are designed to be track- as well as arc-proof. The lower fuse holder additionally functions as push-on type cable termination. Range of application: for Cu or Al cables from 25 up to 240 mm². The earthing switches in the SF₆ chamber enable the HV fuse cartridges to be earthed at both ends. The fuse arrangement is accessible only with earthing switches switched On. **The individual components of the plug-in system can be separated even after years of use since the plug-in surfaces are made of a special combination of materials which prevents sticking.** There is no need to lubricate these surfaces (interfaces). Fuse length: 442 mm; fuses of 292 mm length can be used with an extension adapter.

Fuse selection

Only HRC back-up fuses according to an up-to-date Selection Table No. 12248573 to DIN 43625 up to 88 mm Ø, for the protection of distribution transformers of 6, 12 and 24 kV should be used. Other HRC fuses must be used only after consultation!

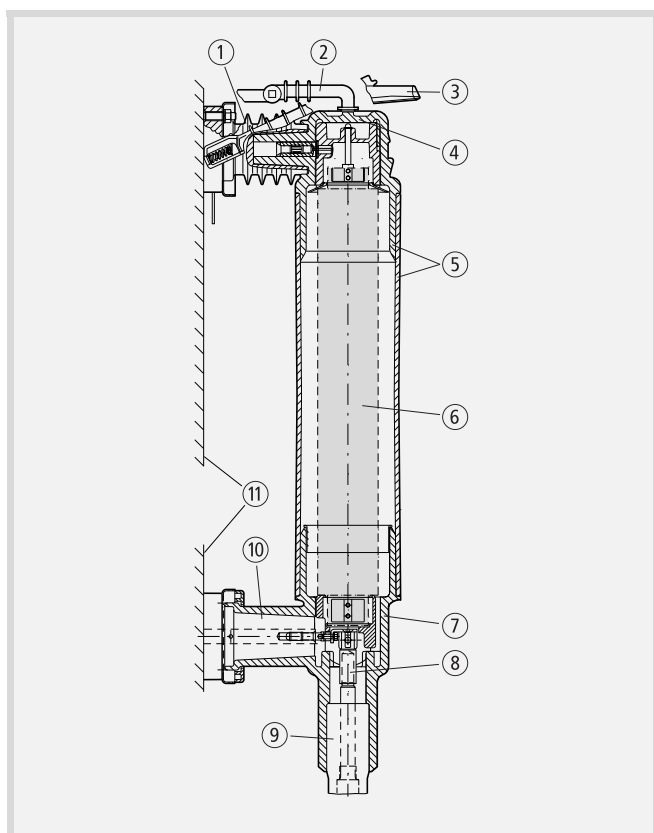

- | | |
|----------------------|--|
| ① Upper bushing | ⑦ Lower fuse holder |
| ② Tripping linkage | ⑧ Cable lug |
| ③ Tensioning lever | ⑨ Stress cone |
| ④ Flexible diaphragm | ⑩ Lower bushing
(2nd earthing switch) |
| ⑤ Upper fuse holder | ⑪ Front gas tank |
| ⑥ HV fuse cartridge | |

Exchanging of HV fuse

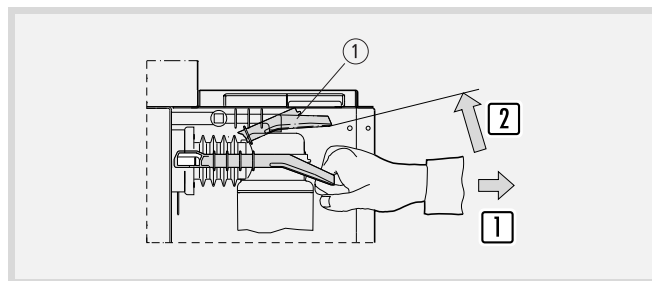

- ① Tensioning lever

Pull tensioning lever forward against the spring pressure, then swing it upwards, into the fuse compartment.

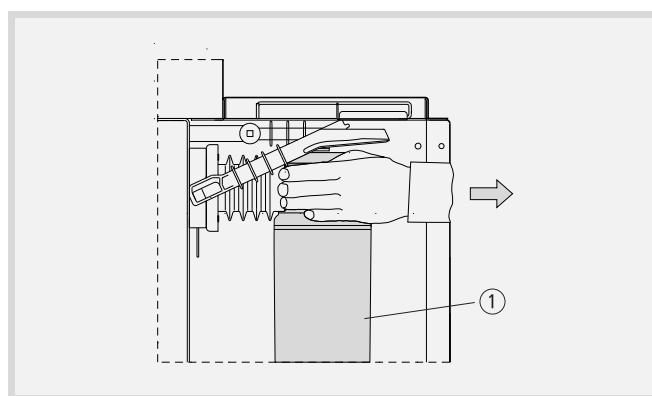

- ① Upper fuse holder

Grasp upper fuse holder and pull it straight out of the upper bushing.

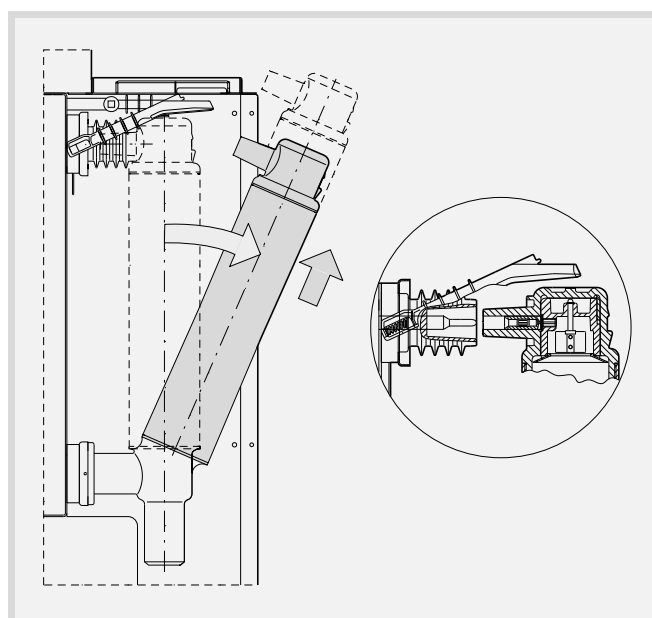

Swing upper fuse holder forward, out of the fuse compartment, then pull it out towards the top, and replace the HV fuse link.

It is not necessary to grease the interface.

To insert a fuse, follow the sequence in reverse.

Medium-Voltage Switchgear up to 24 kV, SF₆-insulated, Modular Design, Type GAE, Series GAE1250

Front panel

Front panel

Front panel with

- Mimic diagram
- Switch position indication
- Operator surface for the actuators
- Capacitive voltage indicators
- Gas leakage indication
- Short-circuit indicators
- Padlocking facility
- Drive sealed against dust, sand and insects
- Housing IP44

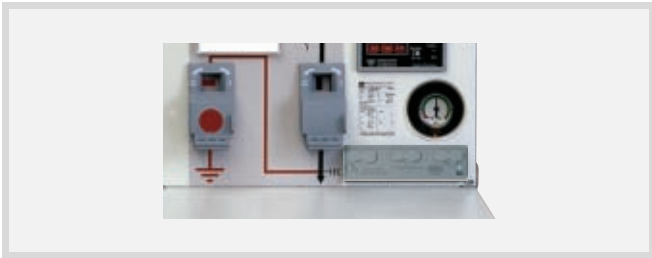

Type -1K-



Type -1TS-

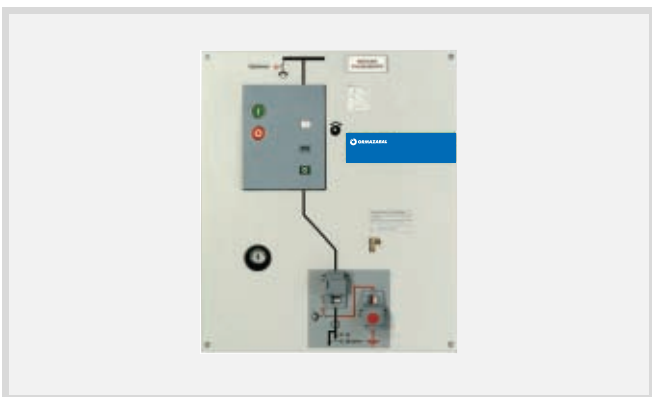

Type -1LSV-

Gas leakage indication

Each gas tank has a pressure display for verification of the SF₆ overpressure within, allowing its functional safety to be inspected.

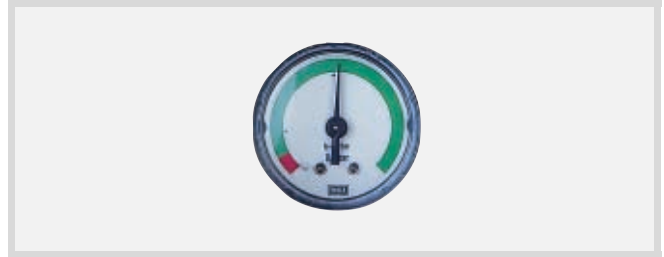

Meaning of the indication:

Green = operating pressure OK

Red = operating pressure not OK.

Pressure switch/ Density monitor

Each gas tank can be fitted with a pressure switch and/or density monitor for remote monitoring (auxiliary contact). The lower switching point corresponds to the crossover point to the red measuring range on the gas leakage indication. The density monitor can be optionally equipped with alarm and tripping indicator auxiliary contacts.

Phase sequence indication



Medium-Voltage Switchgear up to 24 kV, SF₆-insulated, Modular Design, Type GAE, Series GAE1250

Voltage display and testing

Voltage display and testing

Each system is equipped with the necessary three-phase capacitive voltage detection system, Type KSO, for voltage testing to VDE 0682 Part 415 and IEC 61243-5 with HR system (other systems on request). This enables the absence of voltage in individual phases to be verified by inserting the voltage indication plugs into the corresponding pairs of sockets. The voltage detection system circuitry is designed for **rated operational voltages of 10, 15 and 20 kV**. The minimum and maximum values of the Standard for these voltage ranges are adhered to in the standard system. It is not necessary therefore to adjust them again when changing the rated operational voltage within this range. Rated operational voltage 6 kV can be implemented in a special version. The live contact sockets are touch-protected.

Voltage detection system in sealed version



Voltage indication plug

(Picture shows Horstmann device)

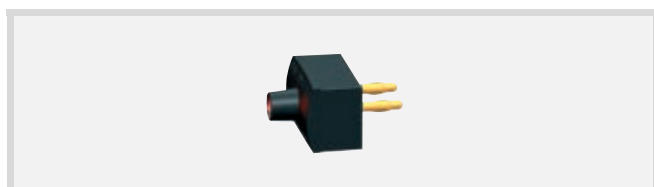

The following devices may be used:

Pfisterer	Type DSA-2
Horstmann	Type HO-ST-1
ELSIC	Type HO-SA
Jordan	Type DSP-HR
Dehn	Type DEHNcap/P-HR

Indication devices are also suitable for continuous duty.

Single-line diagram of a voltage indicator

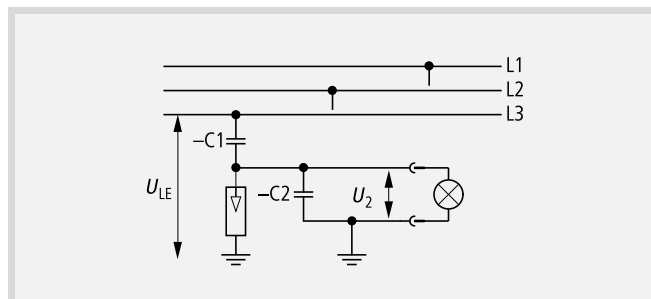

Voltage indication via capacitive voltage divider, HR system. Voltage indication plugged in.

C₁ Capacitor integrated in the bushings.

C₂ Capacitance of the connecting cables and the voltage indication device to earth.

$U_{LE} = U_N / \sqrt{3}$ During rated operation in a three-phase system.

$U_2 = U_A =$ Voltage at the capacitive interface of the system or at the voltage indication device.

Phase sequence indication by interface tester

(Picture shows Horstmann device, Type ORION 3.0)



The following devices may be used:

Make	Phase sequence indication	Interface tester
Horstmann	–	H-OM measuring module with Fluke ammeter Type 87 or matrix Type Mx55 (II to IV)
Horstmann	Type: Orion	Type: Orion
ELSIC	Type: HO-PV	–
Pfisterer	Type: EPV	Type: Euro test-HO
Jordan	–	Type: KSP-HR
Kries	Type: CAP-Phase	Type: CAP-Phase

Medium-Voltage Switchgear up to 24 kV, SF₆-insulated, Modular Design, Type GAE, Series GAE1250

Voltage display and testing

Capacitive voltage indication ledge with built-in three-phase continuous indication and permanent self monitoring

The devices have built-in three-phase continuous indication. For this reason, no voltage indicator devices are necessary. No retesting is required, since the devices are permanently self-monitoring and the LC display shows whether the phase signals are of sufficient magnitude at any one time. If the relevant phase signal is satisfactory, then the full lightning symbol is shown when the nominal voltage U_N of the supply system is present.

The devices have an **integrated three-phase measuring point**. It is matched to the LR requirements in accordance with VDE 0682 Part 415 and IEC 61243-5 and is suitable for phase testing by means of phase sequence indication, as well as for redundant voltage- and retesting, e.g. by means of display unit or interface tester, devices for these purposes (→Page 28).

Device types

There are two device types:

- **CAPDIS-S1+** – Standard version.
No auxiliary voltage required.
- **CAPDIS-S2+** – Version with relay.
Two indicator relays are built in for remote monitoring of voltage conditions. Relay 1 is activated when all conductors are de-energized. Relay 2 is activated when all conductors are energized. For these relays, an auxiliary voltage of 24 V DC is required.

Function and technical data of the devices¹⁾

CAPDIS-S1+ and CAPDIS-S2+	<ul style="list-style-type: none"> • $U < 10\%$ von U_N • de-energized 	no indication
	<ul style="list-style-type: none"> • $10\% \times U_N \leq U \leq 45\% \times U_N$ • voltage present 	indication half lightning symbol
	<ul style="list-style-type: none"> • U_N present • Retesting failed • Phase signal not OK 	
CAPDIS-S2+	<ul style="list-style-type: none"> • U_N present • Retesting passed • Phase signal OK 	indication full lightning symbol
	<ul style="list-style-type: none"> • $U < 10\%$ von U_N • $L1 = L2 = L3 = 0$ (de-energized) 	Relay 1 actuated
	<ul style="list-style-type: none"> • $U > 10\%$ of U_N • $L1 = L2 = L3 = 1$ (voltage present) 	Relay 2 actuated
	<ul style="list-style-type: none"> • 24 V DC $\pm 10\%$ • Auxiliary voltage, potential isolated 	–

U = voltage

U_N = nominal voltage of the supply system (6, 10, 15 kV)

1) VDE 0682 Part 415, IEC 61243-5 (integrated voltage testing system)

Single-line diagram of capacitive voltage indicator with three-phase continuous indication and permanent self monitoring Type CAPDIS-S1+ and version with additional relay contacts Type CAPDIS-S2+

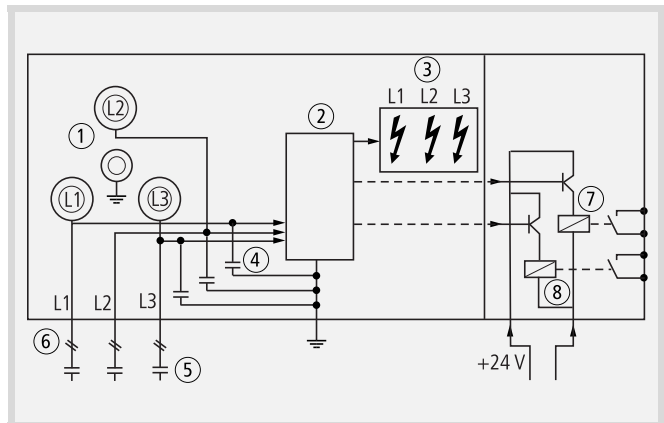

CAPDIS-S1+ and CAPDIS-S2+

- ① Three-phase measuring point
- ② Sensor
- ③ LC display
- ④ Adaption capacitors
- ⑤ Coupling capacitors
- ⑥ Connecting cable

CAPDIS-S2+

- ⑦ Relay 1
 $L1 = L2 = L3 = 0$
(de-energized)
- ⑧ Relay 2
 $L1 = L2 = L3 = 1$
(voltage present)



Voltage detection system Type CAPDIS-S1+¹⁾ – Three-phase measuring point, covered



Voltage detection system Type CAPDIS-S1+¹⁾ – Three-phase measuring point, accessible

1) Alternatively, other types of voltage detection system can be used.

Medium-Voltage Switchgear up to 24 kV, SF₆-insulated, Modular Design, Type GAE, Series GAE1250

Short-circuit/earth-fault indicator

Short-circuit/earth-fault indicator

All ring cable panels can be equipped either with a 3-phase short-circuit or earth-fault indicator.

Manufacturer	Type
Horstmann	ALPHA M
	ALPHA E
	APLHA automatic
	DELTA M
	DELTA E
	EKA-3
	EKA 3/1
	GAMMA 4.0
	Opto
Sigma	
Kries	IKI-10V2SP
	IKI-20B1

Other types and products on demand.



T connection fittings

T connection fittings are to be used as the operator thinks fit. Connectable to bushings to DIN EN 50181 connection type C (630A) with external cone and bolt contact (M16).

With non-controlled systems, the manufacturer's mounting instructions are to be adhered to implicitly.

Mounting options for cable connection fittings:

	NKT/F&G type		ABB type		Tyco Electronics Raychem type		Euromold/Nexas type		Prysmian type	
	10 kV	20 kV	10 kV	20 kV	10 kV	20 kV	10 kV	20 kV	10 kV	20 kV
XLPE- cable	CB12	CB24	SET12	SET24	RSTI	RSTI	K400TB	K400TB	FMCTs400	FMCTs400
	CC12	CC24	SEHDT13	SEHDT23	RICS...	RICS...	K400TB	K400TB	FMCTj400	FMCTj400
	CB36	CB36	SEHDT13.1	SEHDT23.1	–	–	AGT10/630	AGT20/630	–	–
	AB12	–	–	–	–	–	AGTL10/630	AGTL20/630	–	–
	AC12	–	–	–	–	–	–	–	–	–

Medium-Voltage Switchgear up to 24 kV, SF₆-insulated, Modular Design, Type GAE, Series GAE1250

Accessories for the system

Accessories for the system

Operating levers

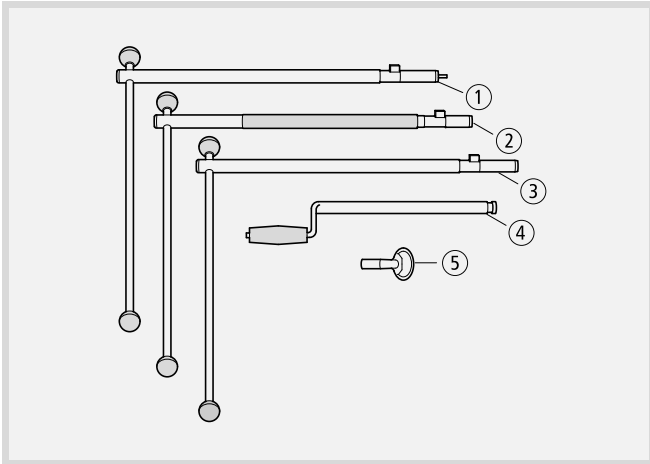

Operating levers, keys for fasteners

- ① Operating lever (optional) for the load-break switch actuating shaft with motor operator (for manual switching e.g. in case of loss of supply voltage).
- ② Operating lever for the earthing switch (optional red shaft).
- ③ Operating lever for the load-break switch (optional plain shaft).
- ④ Charging handle for vacuum circuit-breakers
- ⑤ Key for the fastener on the front cover (controls the anti-reverse interlock).

Cable clamps

Size I

Clamping range 26 to 55 mm for cables, such as

- 12 kV: $35 \text{ mm}^2 \leq 240 \text{ mm}^2$
- 24 kV: $25 \text{ mm}^2 \leq 185 \text{ mm}^2$

Size II

Clamping range 36 to 52 mm for cables, such as

- 12 kV: $\geq 300 \text{ mm}^2$
- 24 kV: $\geq 240 \text{ mm}^2$

The precise cable diameter must be compared with the clamping range.

Coupling and bolt connection kits

Busbar coupling kit with double gasket



Shown: 1 phase

Busbar end cover with single gasket



Shown: 1 phase

Parts for bolt connection of panels



Shown: 1 set

Medium-Voltage Switchgear up to 24 kV, SF₆-insulated, Modular Design, Type GAE, Series GAE1250

Accessories for the system

Arc fault protection, panel installation

For standard panel version with pressure relief into the cable well or cable duct.

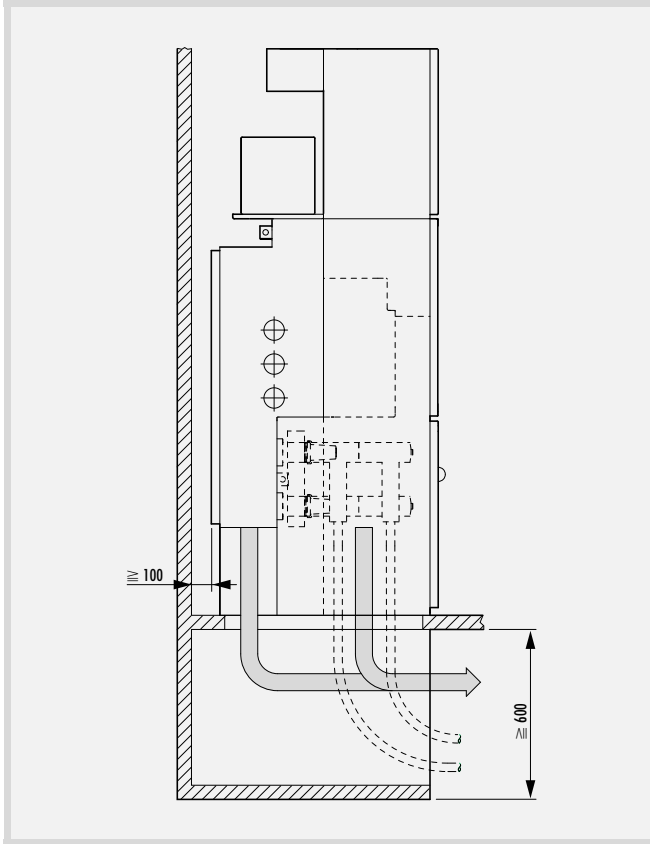

Pressure relief into the cable well or cable duct

For panel version for pressure relief via rear towards the top (panel for floor bulkhead).

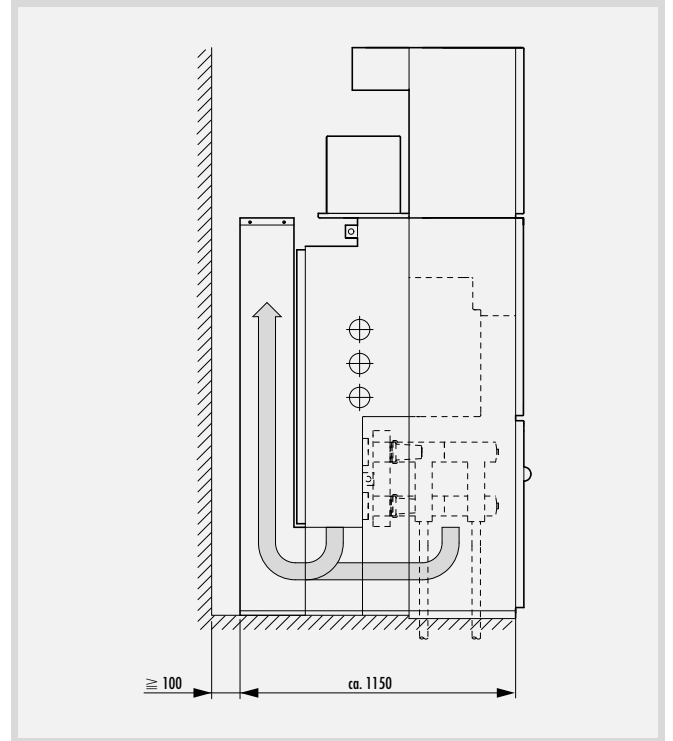

Pressure relief via rear absorber channel towards the top

Switchgear related pressure calculations can be enquired as part of services at the sales department of Ormazabal GmbH.

Medium-Voltage Switchgear up to 24 kV, SF₆-insulated, Modular Design, Type GAE, Series GAE1250

Protection technology

Protection technology

All commercially available protection relays can be installed in the type GAE1250 switchgear for the LSV circuit breaker panels and LSF circuit breaker panels.

The variants range from transformer-operated protection relays to combined protection and control systems.

Low energy trips 0.5 VA and 0.1 VA are available for the transformer-operated relays.

In this context special relay-transformer combinations are tested.

Common protocols and interfaces, e.g. Profibus DP, Modbus, IEC 60870-5-103, IEC 60870-5-101 and IEC 61850 can be provided with related relays.

Installation is in low-voltage compartment / relay niche.

Optionally, the protection relay can also be installed in the related cover.

It is also possible to configure the parameters for the protection relay in accordance with customer requirements.

A few commercially available protection relays as examples:

Transformer supplied:



SEG type WIC

- SEG type WIC
- SEG WIP
- Siemens type 7SJ45
- Areva type P114S



Siemens type 7SJ45

Supplied with external power:

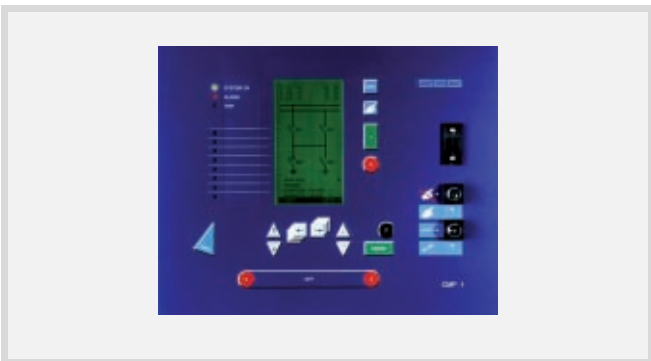

SEG Typ CSP/CMP

- SEG type CSP/CMP
- Siemens type 7SJ63
- ABB type REF542plus
- Areva type P139



ABB type REF542plus

Notes

Notes

Technical-Commercial Department

Tel.: +34 94 431 87 31

Fax: +34 94 431 87 32

E-Mail: oib@ormazabal.com

www.ormazabal.com

• SF₆-insulated switchgear



- type GA
- type GAE
- type CPG.0
- type CPG.1

■ Air-insulated switchgear

- type EA
- type AMC

■ Air-insulated switches

- type NVL
- type KL(F), T, DES

